



(Technical Pioneers of the Energy Transition)

Grid Stability with Renewable Power Integration **on 22nd May 2026**

Date: 22-05-2026

Overview of Regional Grids and RE(Solar & Wind) Potentials

Solar Radiation Atlas

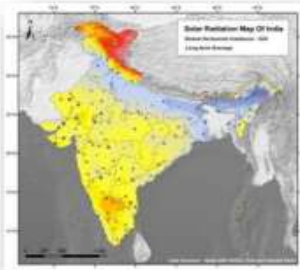

Wind Atlas

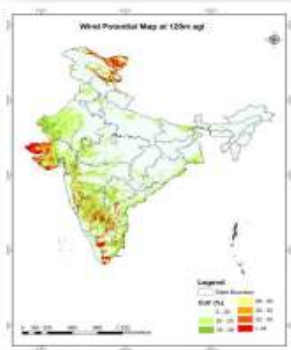

Offshore Wind



High Wind and Solar potential in Southern, Western, Northern Regions

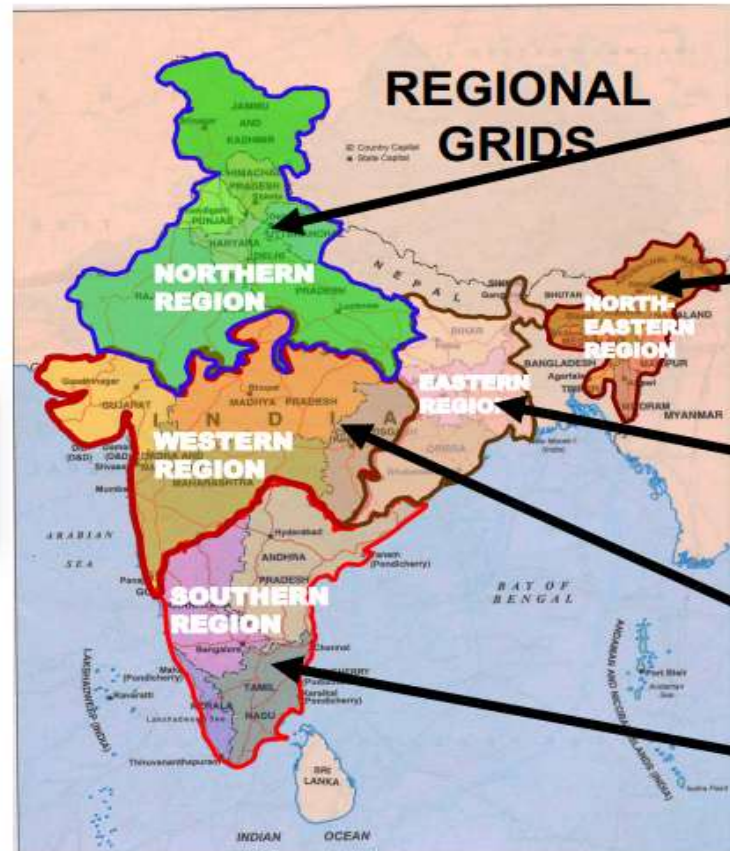

- Snow fed – run-of –the –river hydro**
Highly weather sensitive load
Adverse weather conditions: Floods, Fog & Thunderstorms
High RE in Rajasthan
- High hydro potential**
Mountainous Terrain
Power evacuation challenge
- High coal reserves**
Pit head base load plants
- Industrial and Agricultural load**
Renewable Rich States – Wind/Solar
Large thermal generation capacity
- Industrial and Agricultural load**
Monsoon dependent hydro
Renewable Rich States – Wind/Solar

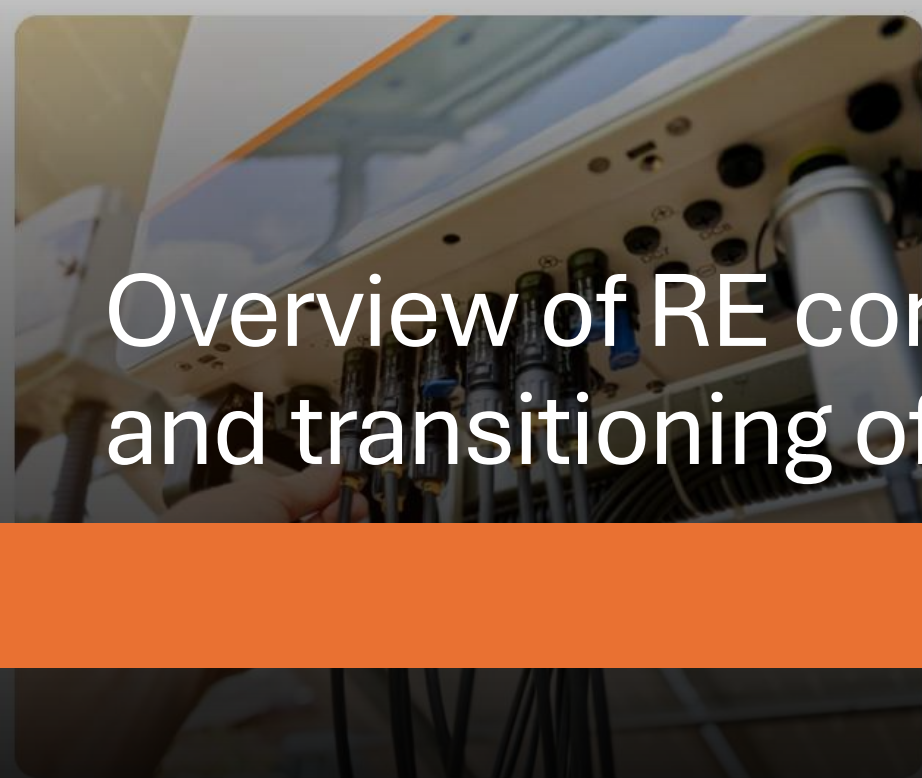

Overview of RE commissioned Capacity and transitioning of Grid N\w in NR



RE Addition with time and All time high penetration figures

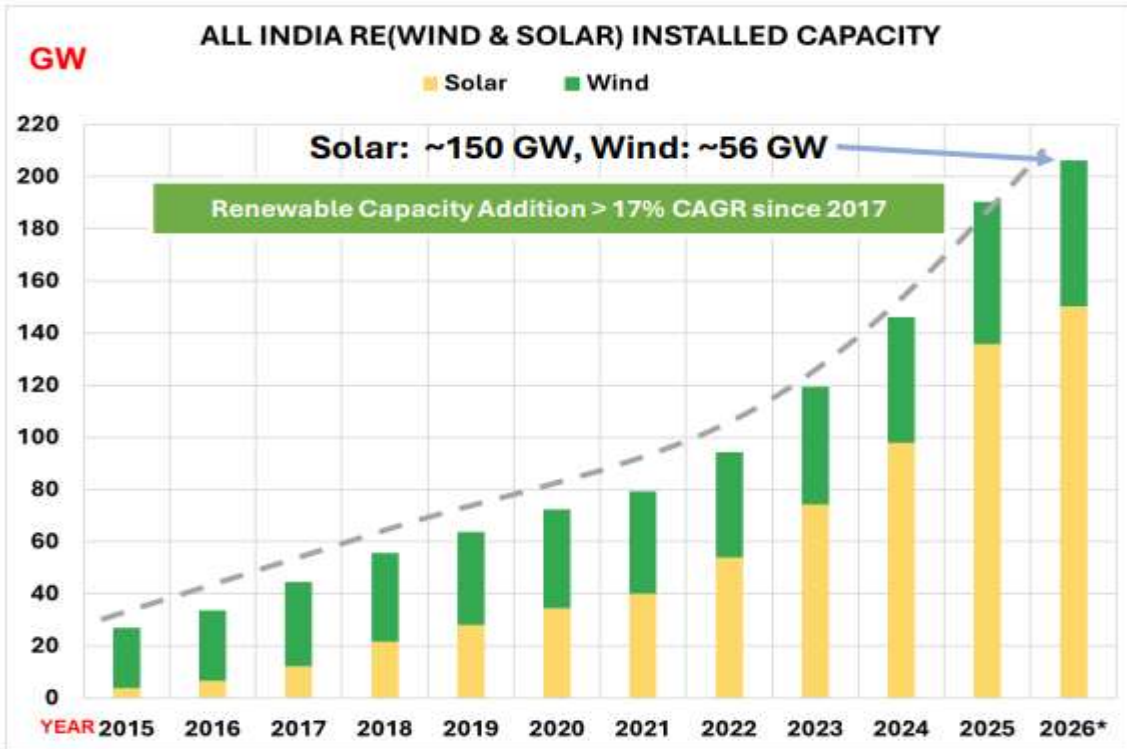

Source: CEA Installed Capacity Report (data as on Dec 2025)
[Installed Capacity Report - Central Electricity Authority](#)

Maximum Wind + Solar penetration in instantaneous MW and energy (day/year) terms – FY 2025-26

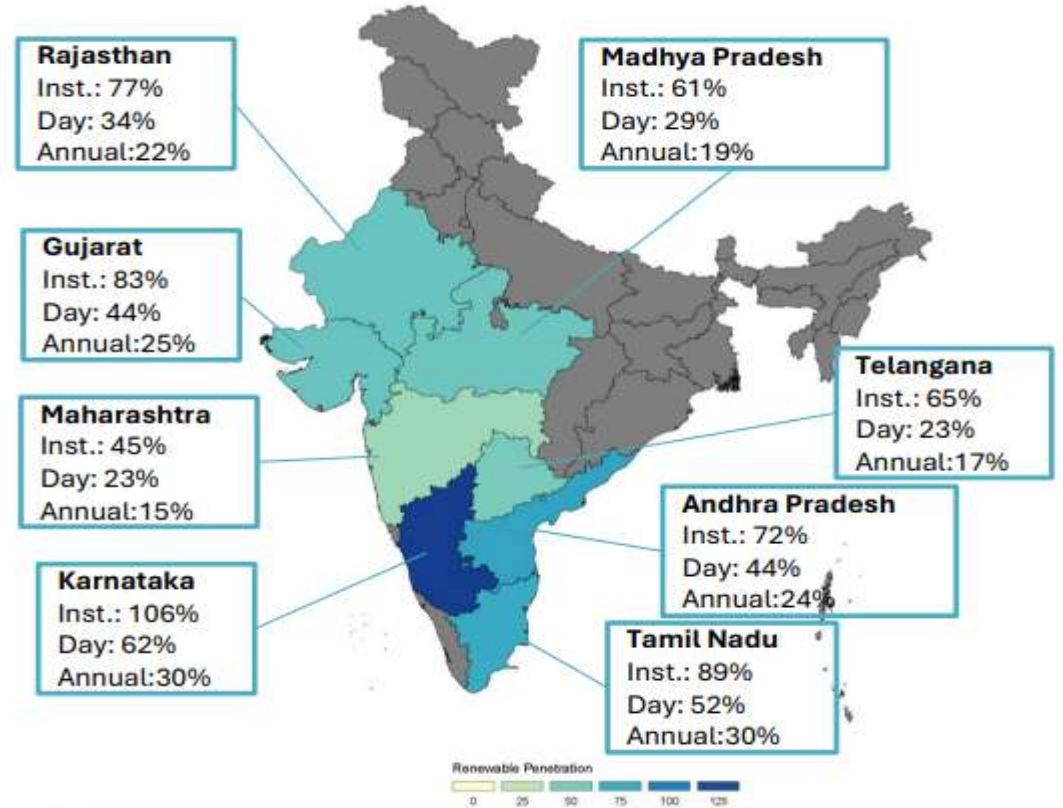

Highest All India Instantaneous VRE (Solar + Wind) penetration of ~40.1% recorded - 2nd June 2025

Highest All India Instantaneous RE (Solar + Wind + Hydro) penetration of ~51% recorded - 6th Sep 2025

500 GW non-fossil capacity by 2030
 Including ~285 GW Solar & ~93 GW Wind

Road Map of Energy Transition 2026->2030->2036





Resource	Mar-2026	Mar-2030	Mar-2036
Hydro (including PSP)	51	81	172
Solar PV	150	285	509
Wind	56	93	155
Other RES	17	18	22
Nuclear	9	13	22
Coal + Lignite	229	260	315
Gas	20	20	20
Total	533	770	1215
BESS	-	24	80

All capacities in GW

Source: CEA LONG-TERM NATIONAL RESOURCE ADEQUACY PLAN (2026-27 to 2035-36)

Rooftop Solar I/C (as on Mar 2026): 25.73 GW

till April 2026* 2030

	Maximum Demand Met (GW)	~256 [#]	334 [^]
	Electricity Consumption for preceding FY (BU)	~1707 [#]	1949 [^]
	Total Generation Installed Capacity (GW)	533 [*]	770
	Non-fossil Fuel Based Generation Installed Capacity (GW)	283	500
	Wind & Solar Installed Capacity (GW)	206	378

Source: [#] Operational Data of Grid-India

^{*} As on Mar 2026, CEA Installed Capacity Report

[^] 20th EPS Survey by CEA

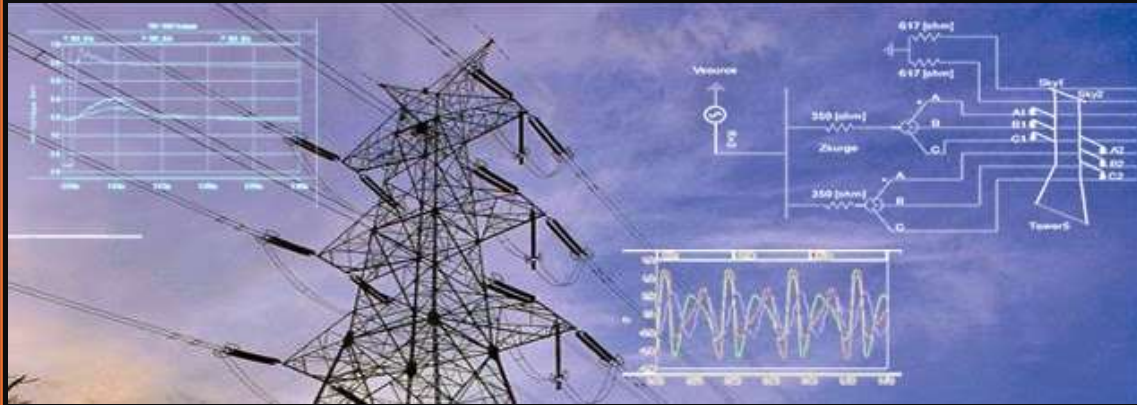

Grid Stability with RE integration

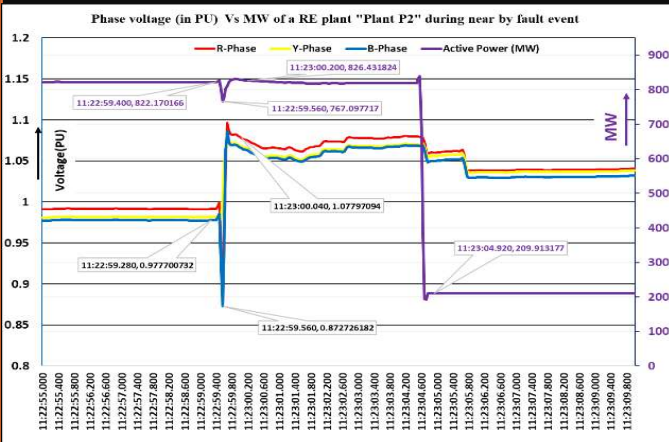

40 GW RE pocket- Rajasthan Case Study

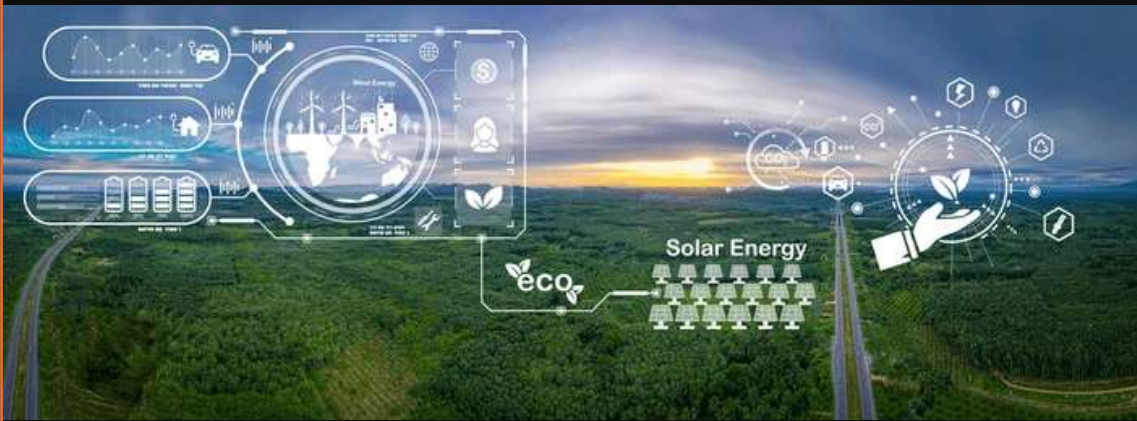

NR RE Pocket evolving in Phases

RE being evacuated through long EHV lines ~500-700 KM from Pooling S/s to load Centre. (A typical complex)

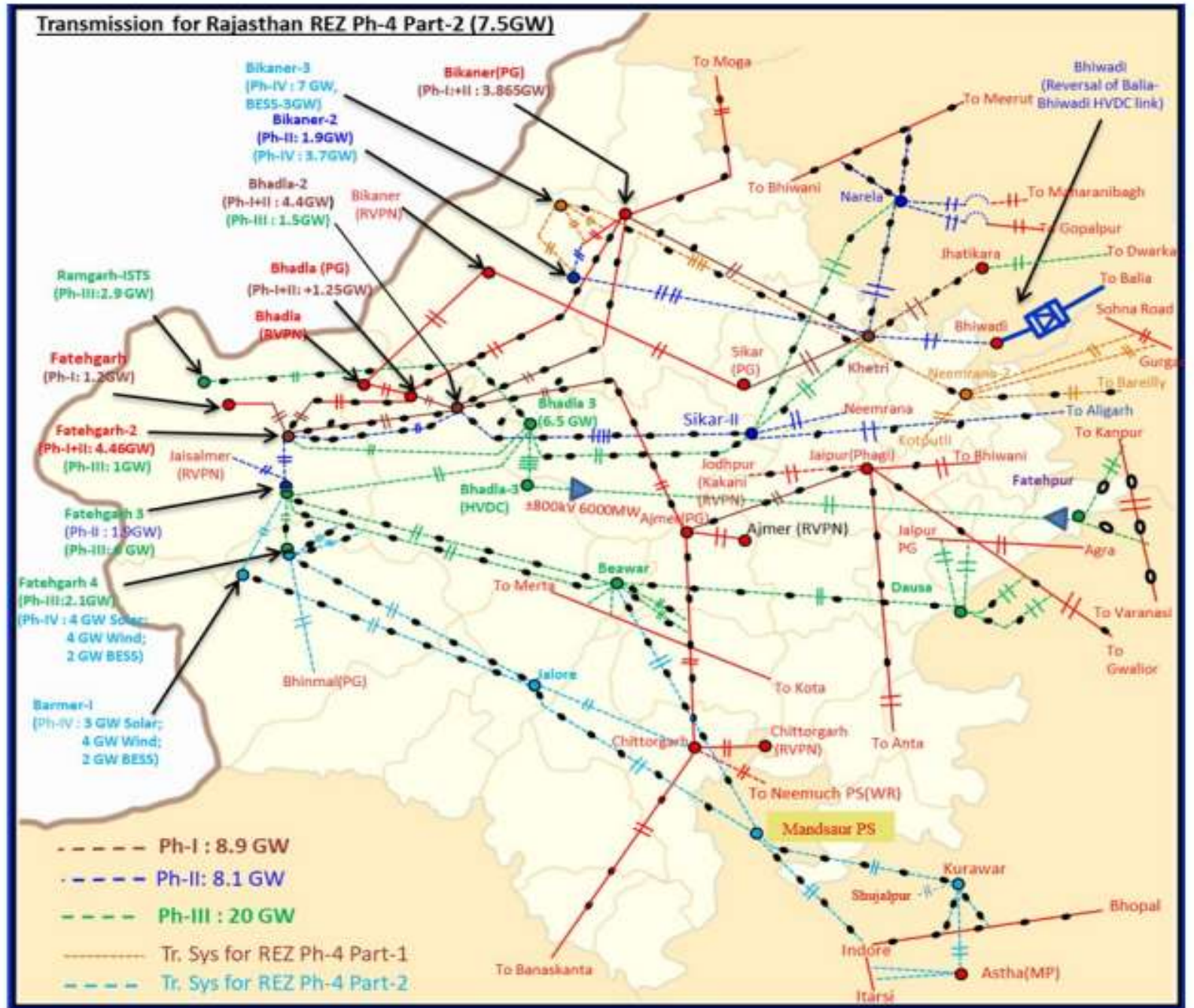

Comparatively Declination of System Strength with Solar Integration

SCR is the ratio of grid short-circuit strength to the rating of the connected converter/ disturbance. (For Example Solar Integration without Transmission addition)

However, due to inter-bus coupling and multi-converter interactions, the effective system SCR may decline substantially compared to the locally estimated SCR at the point of interconnection.

	Initial	After 1500MVA Integration	After Further 2500MVA Integration
Short Circuit MVA	10000	10000	10000
Connected Disturbance	NA	1500	4000
SCR	NA	6.66	2.5

VRE generation & voltages at RE pooling stations

FATEHGARH-2 PG|765_BUS2|PU — BHADLA-2 PG|765_BUS2|PU — BIKANER 765/400|765_BUS1|PU — NR_Total RE Generation MW

Voltage variation in RE pocket from Lightly loaded to Highly loaded lines

- This requires to open the line in voltage regulation in night hours(non- generation hours) to avoid OV trippings and further charging and Switching out of Reactors need to be done timely preferably at low SCR buses.
- In Solar Hours, it requires continuous MVAR support for Voltage stability with increasing penetration in the Grid.

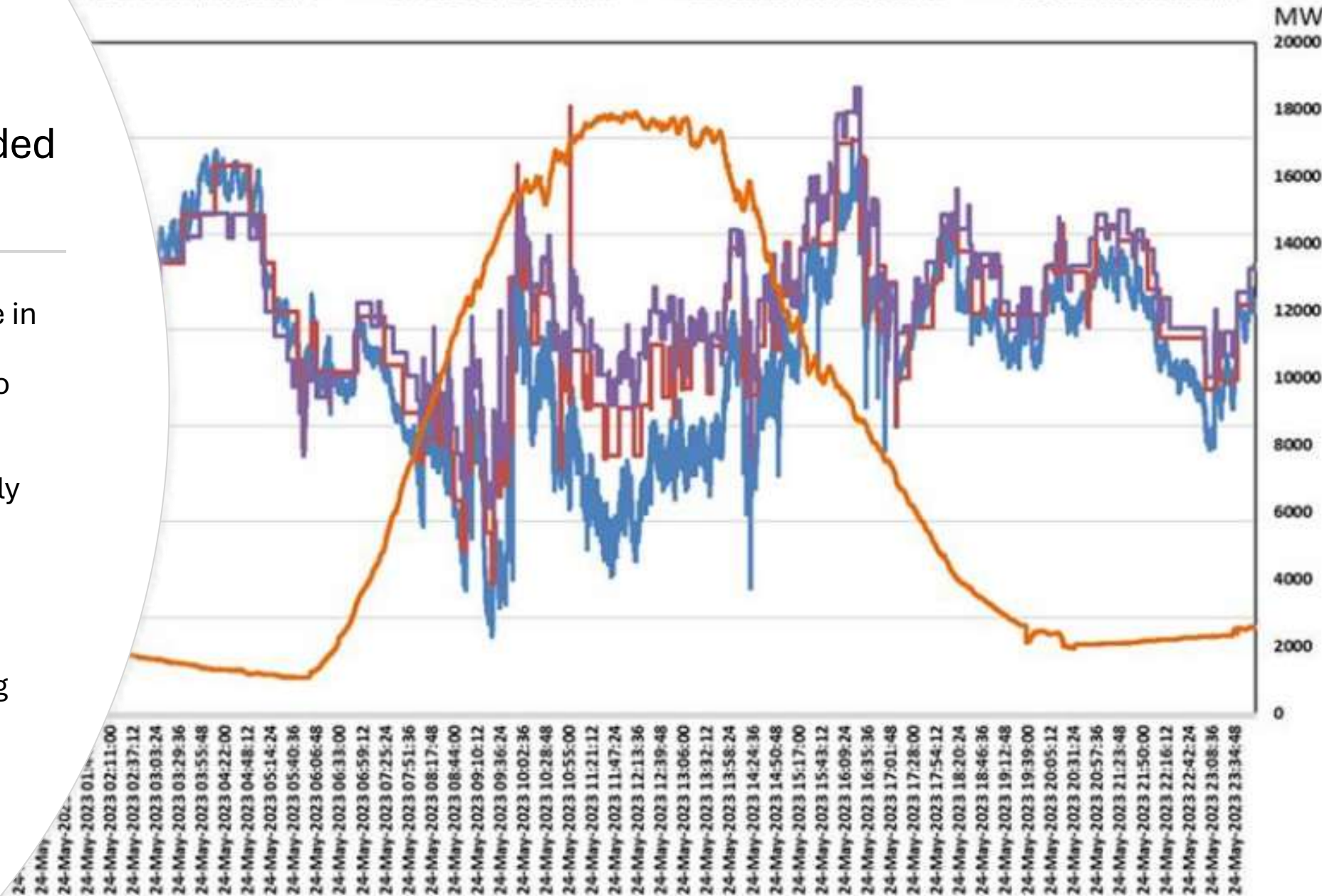

Delayed communication between Multifunction meter->PPC->Inverters

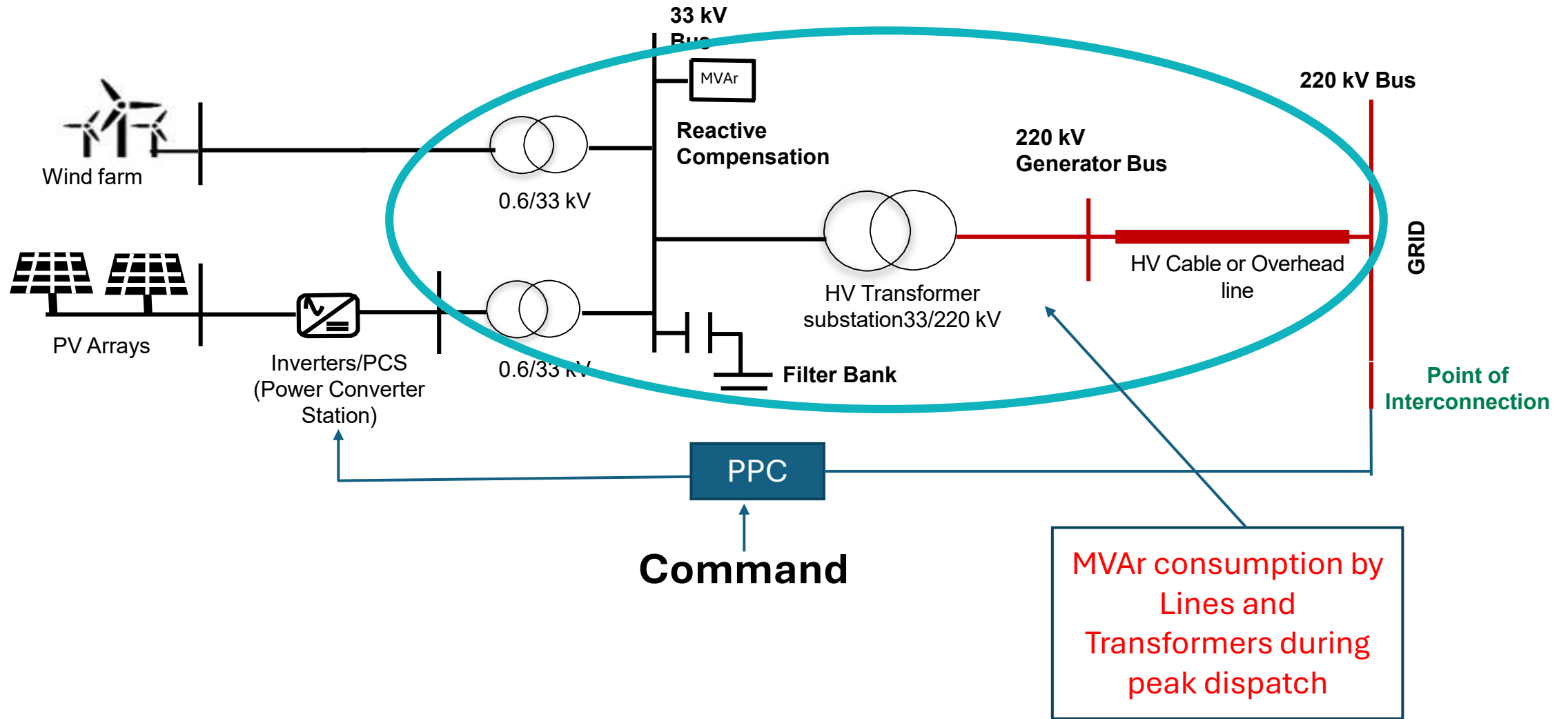

Issues with Reactive power support to the grid

- RE Generators has the MVA constraints for e.g. (i) Equal MW=MVA installation (ii) Inverter degradation on temperature, which causes choice between continue to MVAR injection or Increase MW with increase in radiation\decrease in Voltage.
- In case of Multifunction meter/P-Q meter installed other than POI, then compliance at POI is difficult to achieve.

Plant A

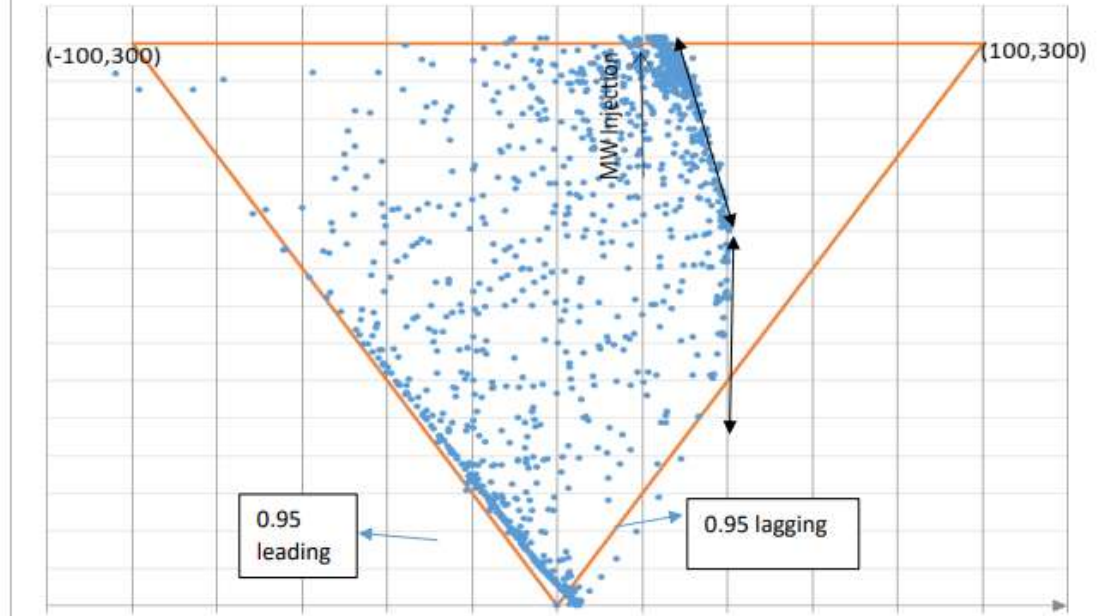

Plant B

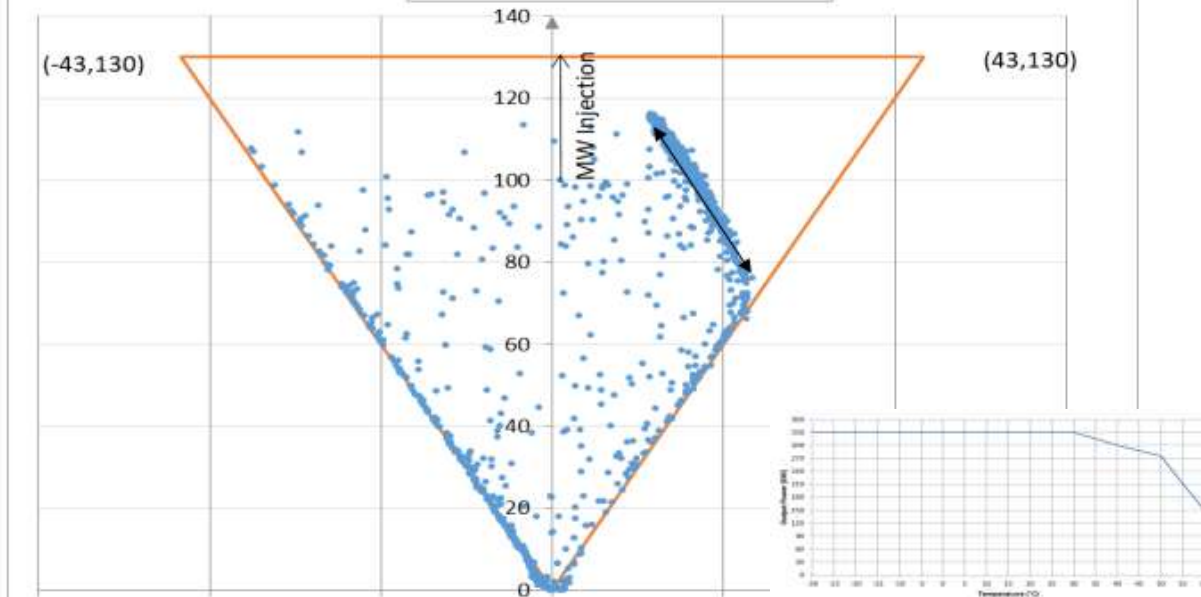

Voltage Oscillations/Fluctuation in Rajasthan RE Complex

Low frequency voltage oscillations (0.1 - 0.2 Hz)

- High RE penetration, low SCR.
- RE plants in voltage control mode
- Different response time of PPCs
- Last occurred on 6th Feb'2026



High frequency voltage oscillations (3.5-5 Hz)

- STATCOM in auto mode + low amplitude high frequency oscillations, low SCR
- Last occurred on 31st Jan'2026



Voltage spikes (70-80kV in 765kV RE pooling S/s bus, no specific frequency)

- All STATCOMs in dead-band mode or Manual Fixed-Q mode, or STATCOM Out (No dynamic MVar support/Stability), Low SCR.
- Last occurred on 4th Feb'2026

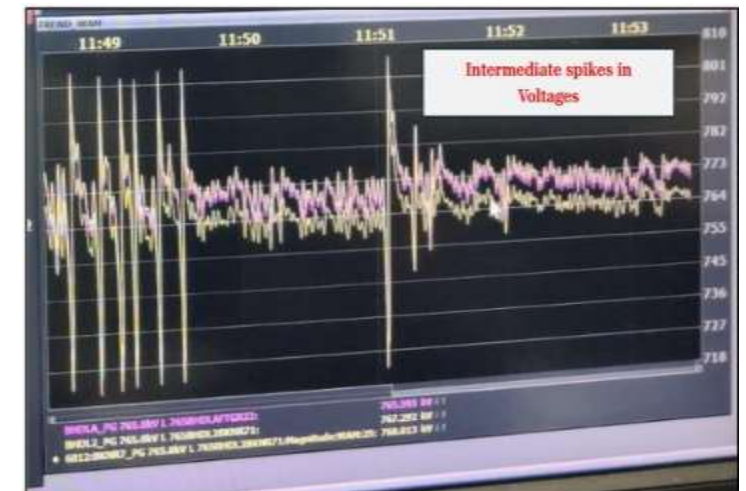

Voltage fluctuation in the grid voltage with Mal-function of a Plant SVG

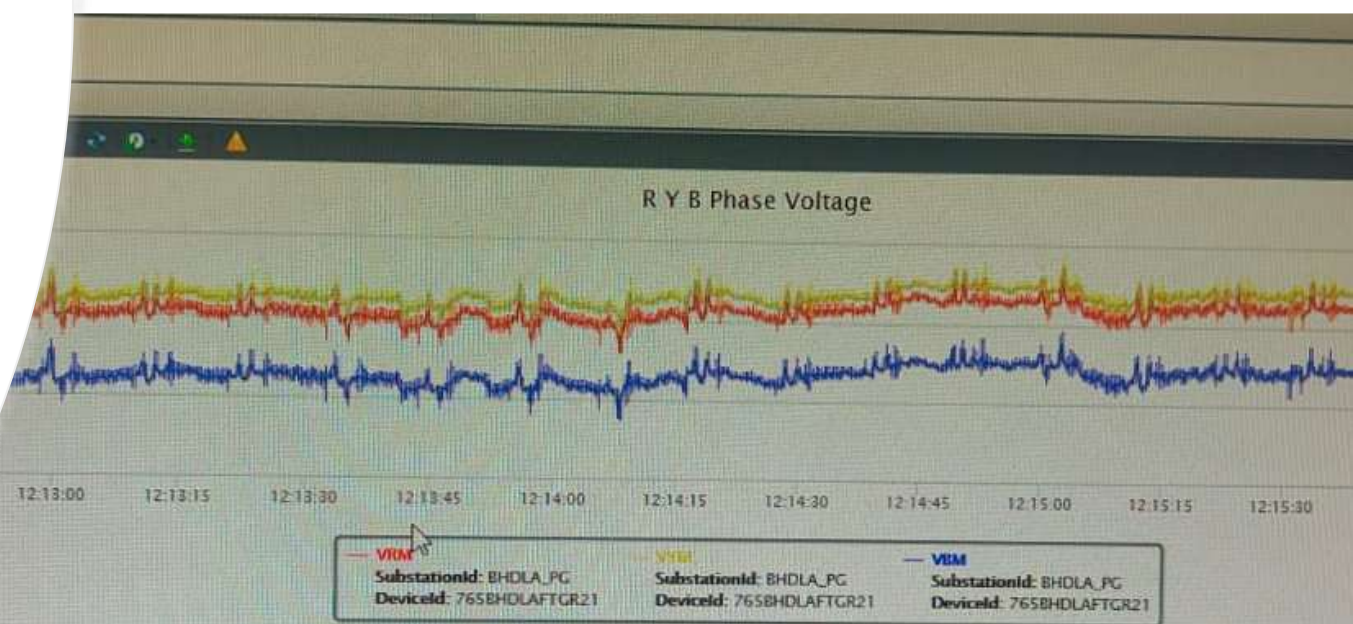

Impact of low SCR and high RE penetration

S. No.	Oscillation event in NR RE complex		Antecedent conditions			Oscillation Details		Major Tr. Line outage
	Event date (dd/mm/yyyy)	Event Time (hh:mm:ss)	ISGS Solar Generation (MW)	Total Wind generation (MW)	Bus Voltage at 400kV Bhadla-II (PG)	Amplitude of Oscillation (kV) (Peak-to-Peak) at 400kV bus	Frequency of Oscillation (Hz)	
1	07.05.2025	10:11:22	16704	26	397	52	3.5-4 Hz	400 kV Jaisalmer (RS) -Barmer (RS) D/C line. 400 kV Barmer - Bhinmal (RS) D/C line. 400 kV BHADLA-JODHPUR (RS) line. 400 kV BHADLA-MERTA (RS) line. 400 kV Akal-Kankani (RS) line.
2	10.05.2025	10:04:20	16701	10	401	32	3.5-4 Hz	400 kV Jaisalmer (RS) -Barmer (RS) D/C line. 400 kV Barmer - Bhinmal (RS) D/C line. 400 kV Akal-Kankani (RS) line.
3	10.05.2025	10:22:20	16737	10	401	20	3.5-4 Hz	400 kV Jaisalmer (RS) -Barmer (RS) D/C line. 400 kV Barmer - Bhinmal (RS) D/C line. 400 kV Akal-Kankani (RS) line.
4	11.05.2025	10:20:22	16580	154	402	27	3.5-4 Hz	400 kV Jaisalmer (RS) -Barmer (RS) D/C line. 400 kV Barmer - Bhinmal (RS) D/C line. 400 kV Akal-Kankani (RS) line.
5	13.05.2025	14:34:48	17412	1670	402	30	3.5-4 Hz	400 kV Jaisalmer (RS) -Barmer (RS) D/C line. 400 kV Barmer - Bhinmal (RS) D/C line.
6	14.05.2025	10:21:00	17728	1456	398	35	3.5-4 Hz	400 kV Jaisalmer (RS) -Barmer (RS) D/C line. 400 kV Barmer - Bhinmal (RS) D/C line.
7	17.05.2025	10:21:08	17843	1667	399	26	3.5-4 Hz	400 kV Jaisalmer (RS) -Barmer (RS) D/C line. 400 kV Barmer - Bhinmal (RS) D/C line.

Way forward

Voltage Oscillations Are Multi-Faceted caused by **control interactions, weak grid strength, reduced inertia, and concentrated IBGs.**

- ✓ **Root Cause analysis by RE plants, Control upgrades and fine tuning of Controllers:**
 - RCA needs to be done by RE plants to identify the exact reason of MVAR fluctuation and Voltage oscillation, to remove unstable control interactions, to Improve voltage damping.
 - Tuning of Voltage loop gain, Current controller gain, PLL bandwidth, Reactive droop constants.
 - Prevents: Over aggressive response, Under-damped oscillations

- ✓ **Grid-Forming (GFM) vs. Grid-Following (GFL)**
 - **GFM inverters emulate inertia and damping**, offering better oscillation suppression compared to traditional GFL controls.
 - GFM with **virtual synchronous machine (VSM)** control enhances voltage stability margins.
 - **Piolet GFM may be deployed in Identified RE plants.**

- ✓ **Power Oscillation Damping Enhancements**
 - Add auxiliary damping control loops (like power oscillation damping or PSS-like schemes) into inverter controls mainly to damp any MVAR fluctuation coming from Inverters.

- ✓ **Deployment of Synchronous condenser:**
 - Synchronous condensers at weak nodes to raise SCR and provide voltage stabilization (used in Australia)

Mitigations Must Be Holistic Control upgrades + system reinforcement + coordinated reactive support + updated operational practices are all essential. **Further, issue of STATCOM's aggressive gain reduction needs to be addressed.**

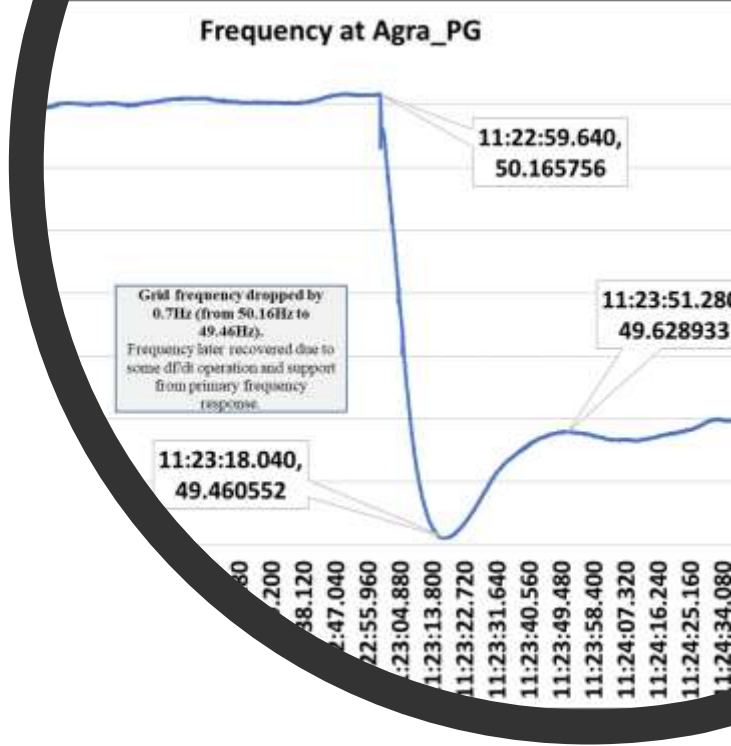
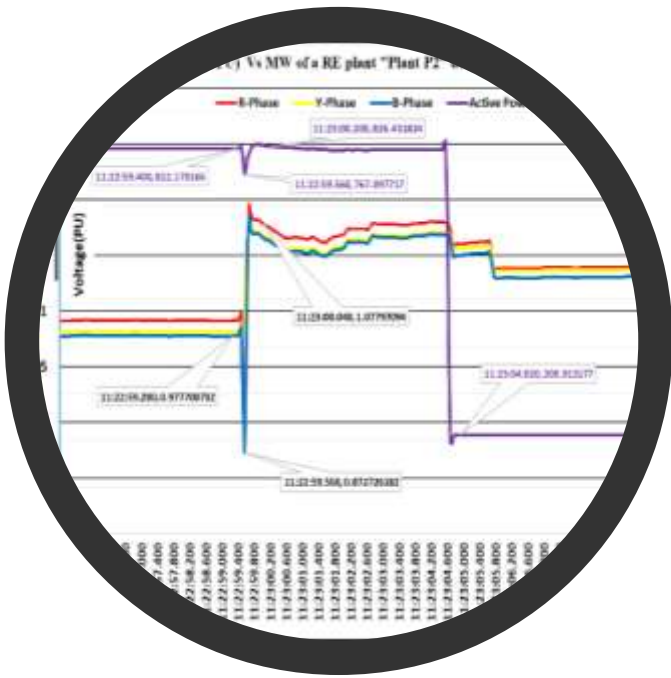
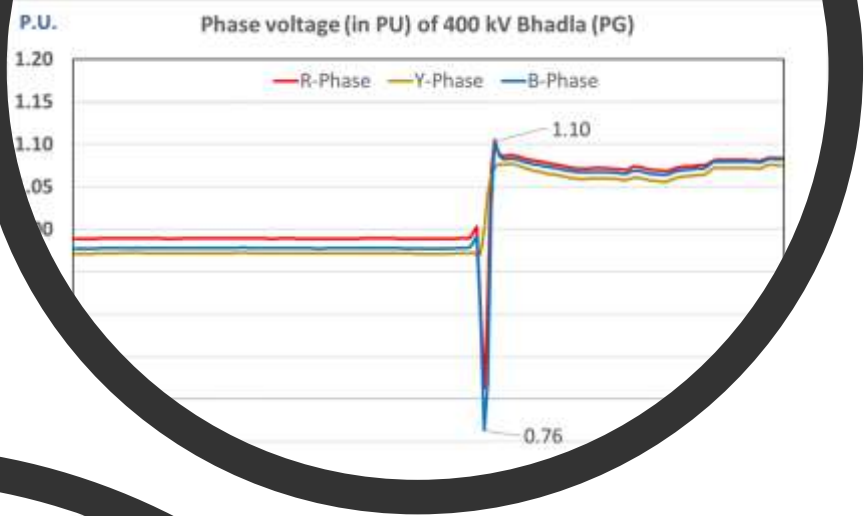

Real-time plant performance during fault event
 Results before and after modification in HVRT

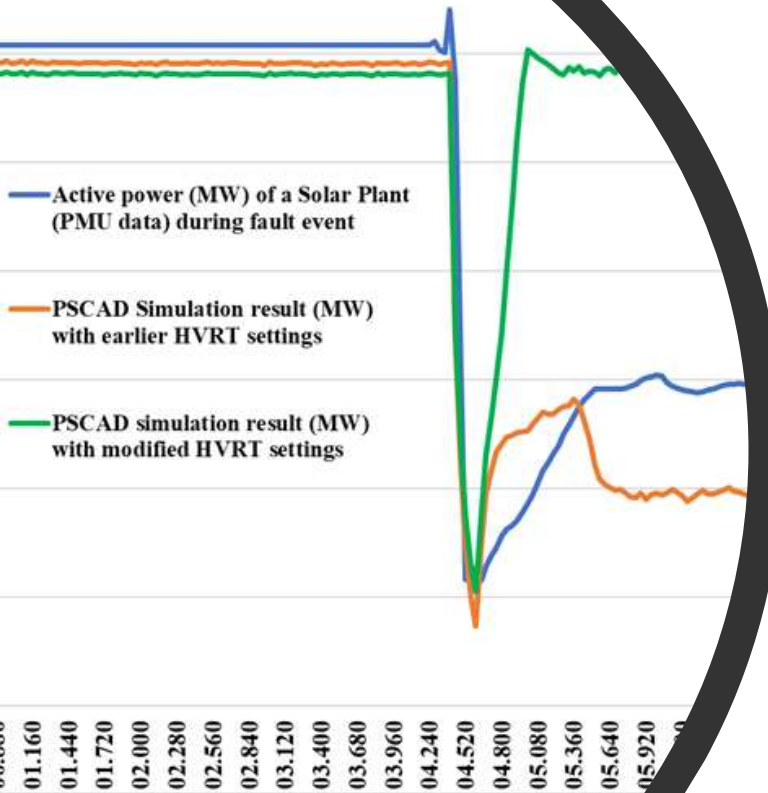

LVRT, HVRT Non-compliance and RE generation loss issues

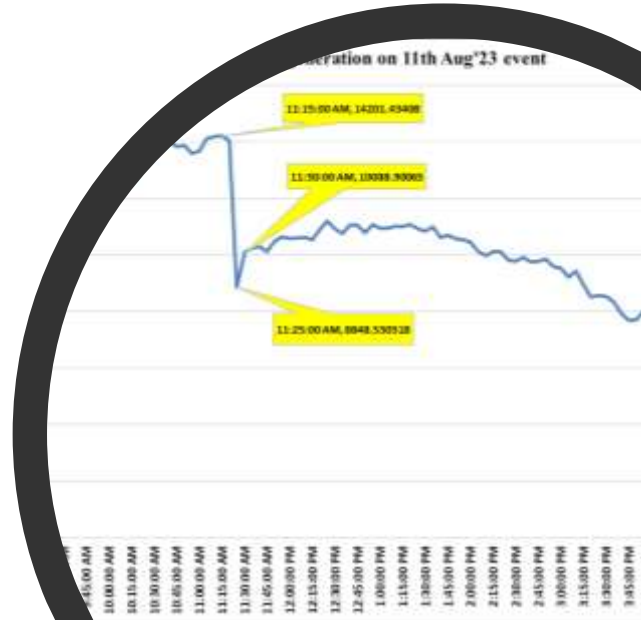

RE Generation loss in case of fault in the vicinity of RE complex

No recover or partial recovery of generation after clearance of fault: **Performance of Plant-P1;**

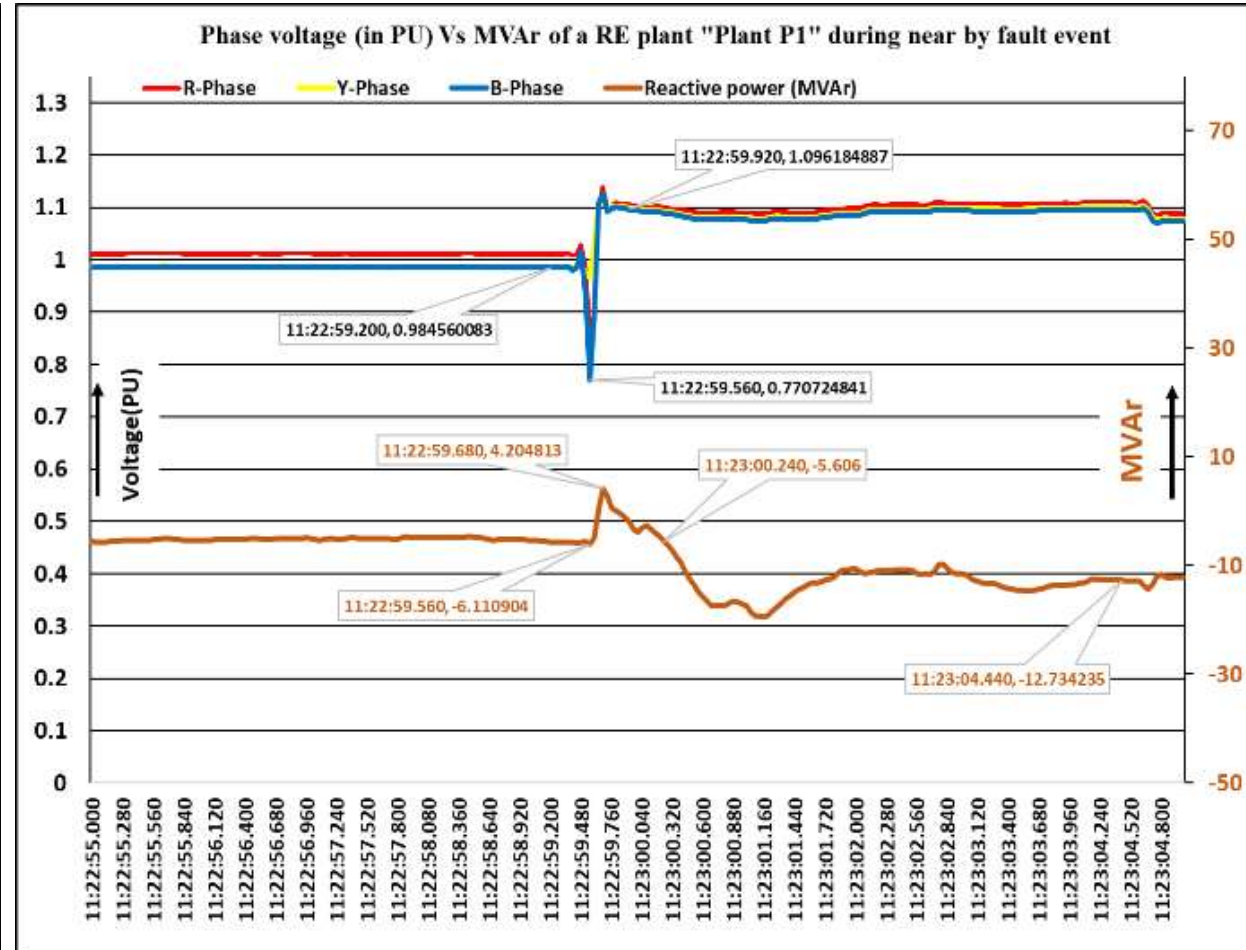
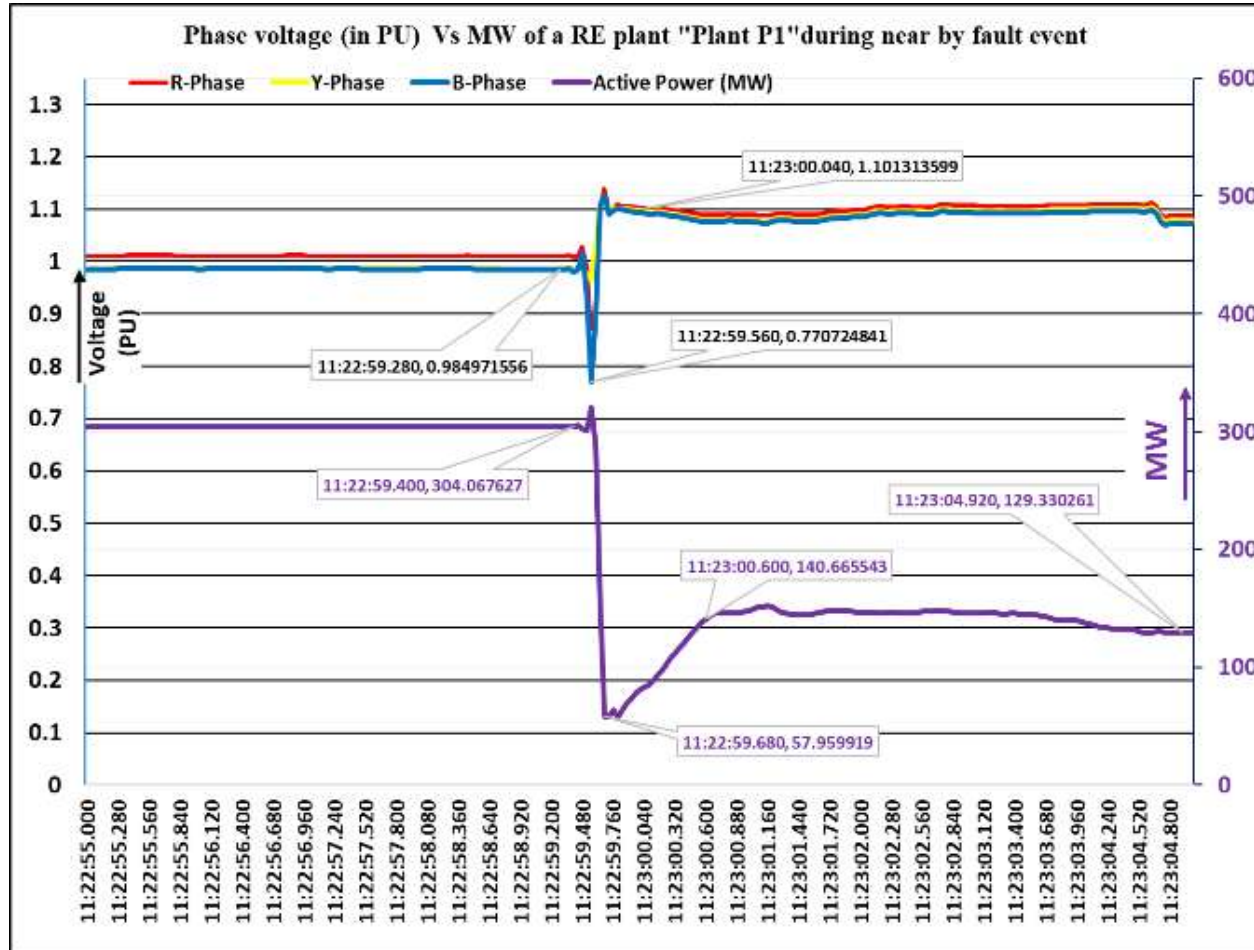

- ✓ Sharp reduction of active power without commensurate reactive power support during the fault event.
- ✓ Active power reduced from 304MW to 58MW during fault and recovered only up to 140MW.
- ✓ No commensurate reactive power support, injection only upto 4MVAR only during fault.
- ✓ De-loading of EHV line and voltage shoot.

RE Generation loss in case of fault in the vicinity of RE complex

Full recovery of pre-fault generation after fault clearance but generation loss after few sec. (3-4sec): **Performance of Plant-P2;**

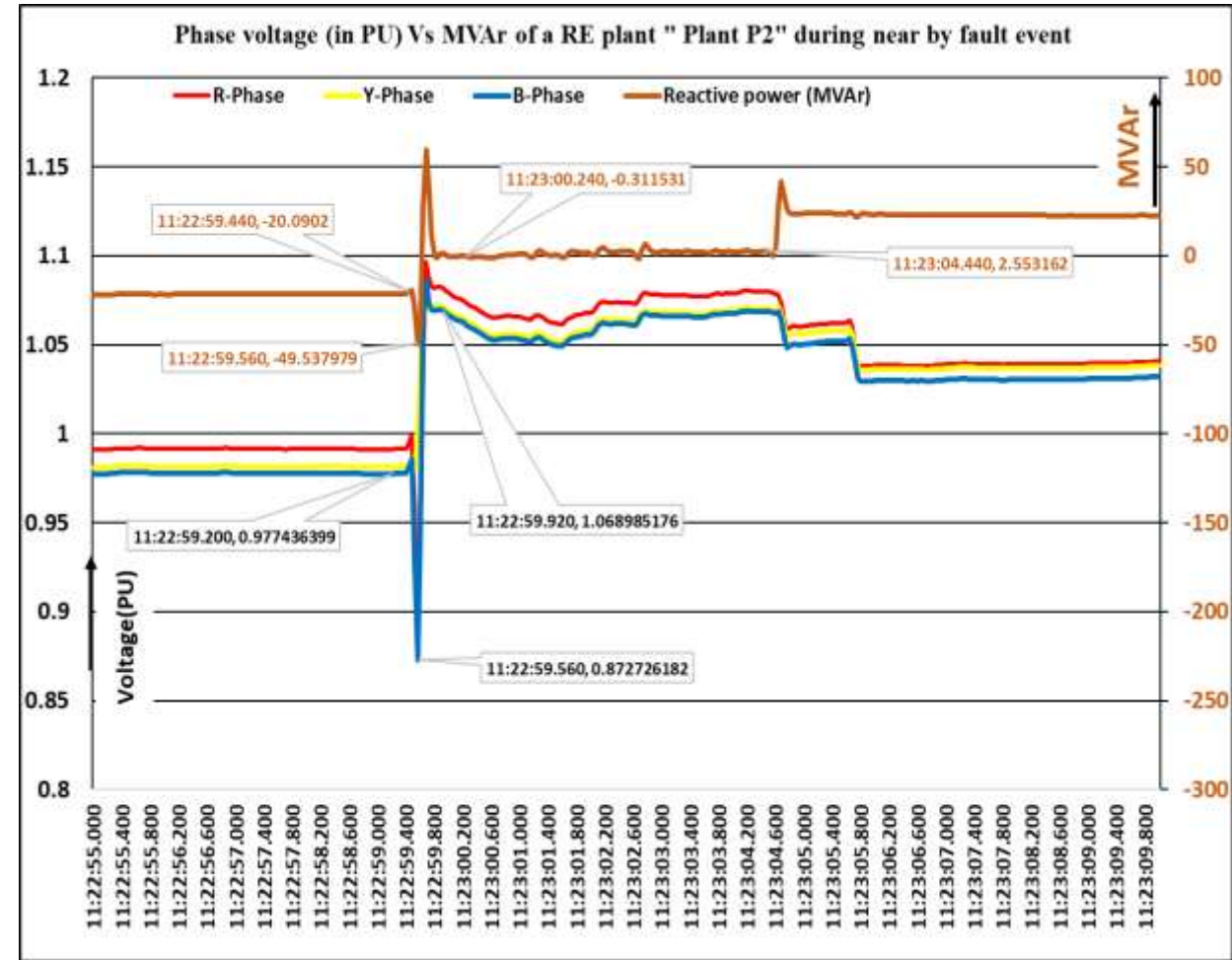
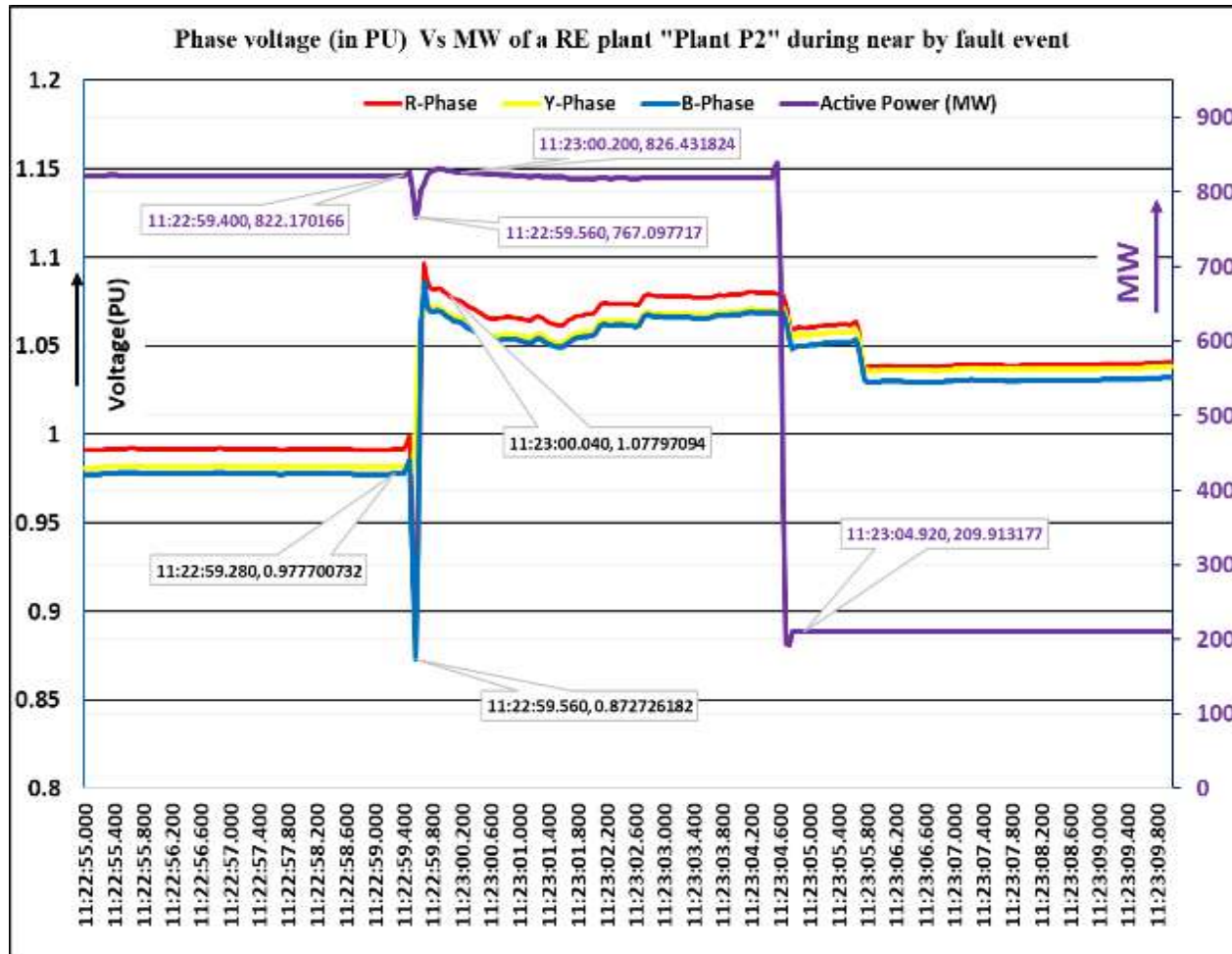

- ✓ Successfully recovered the pre-fault generation. Active power reduced from 826MW to 209MW after ~5sec.
- ✓ No reactive power absorption despite of high voltage. Before tripping in OV, inverters must went in HVRT, it should absorb MVAR but no MVAR absorption observed.
- ✓ Further generation loss and no MVAR absorption leads to sustained high voltage and tripping of EHV lines.

RE Generation loss events in case of reactor switching

Generation loss after 6-7 sec of reactor opening: Performance of Plant-P3;

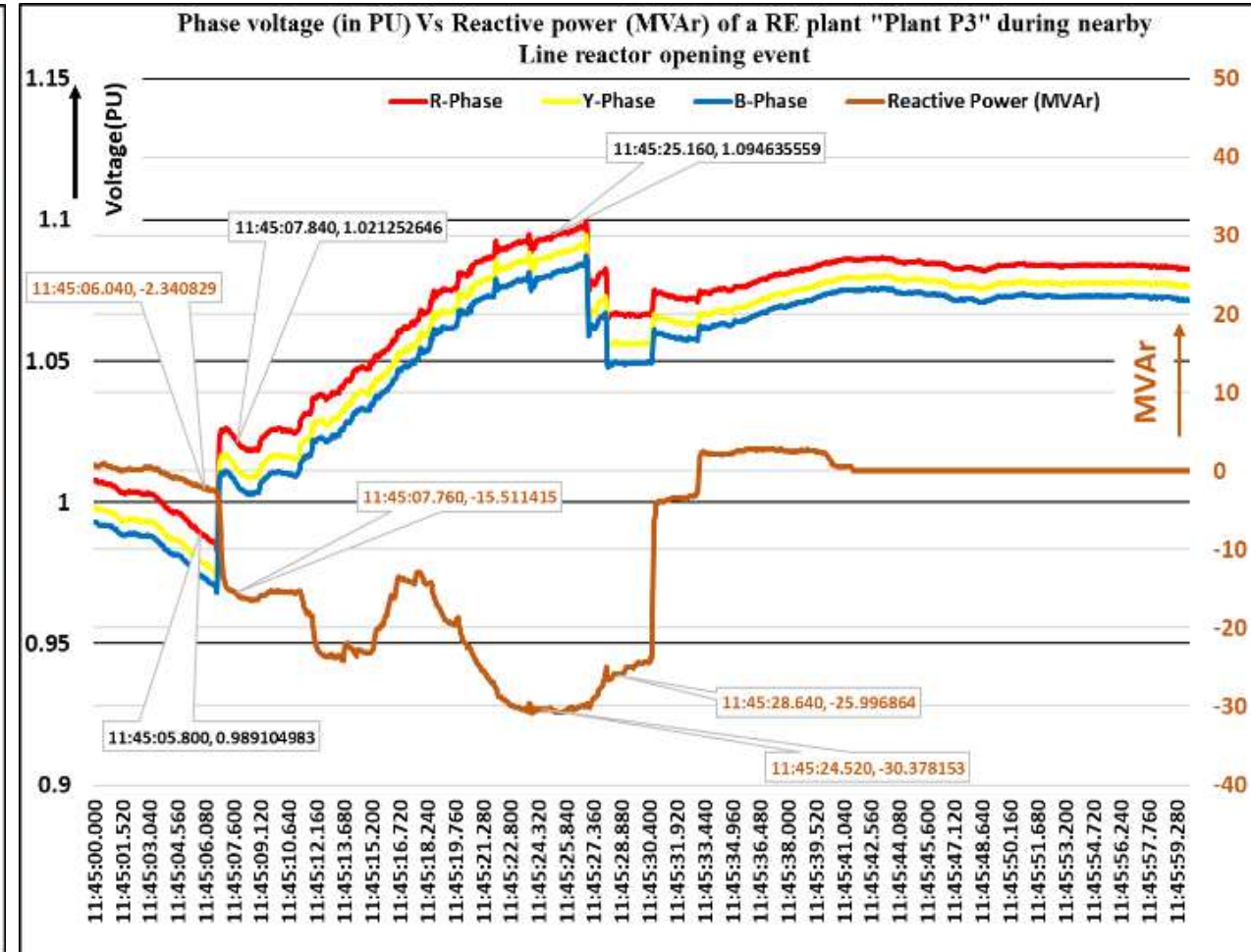
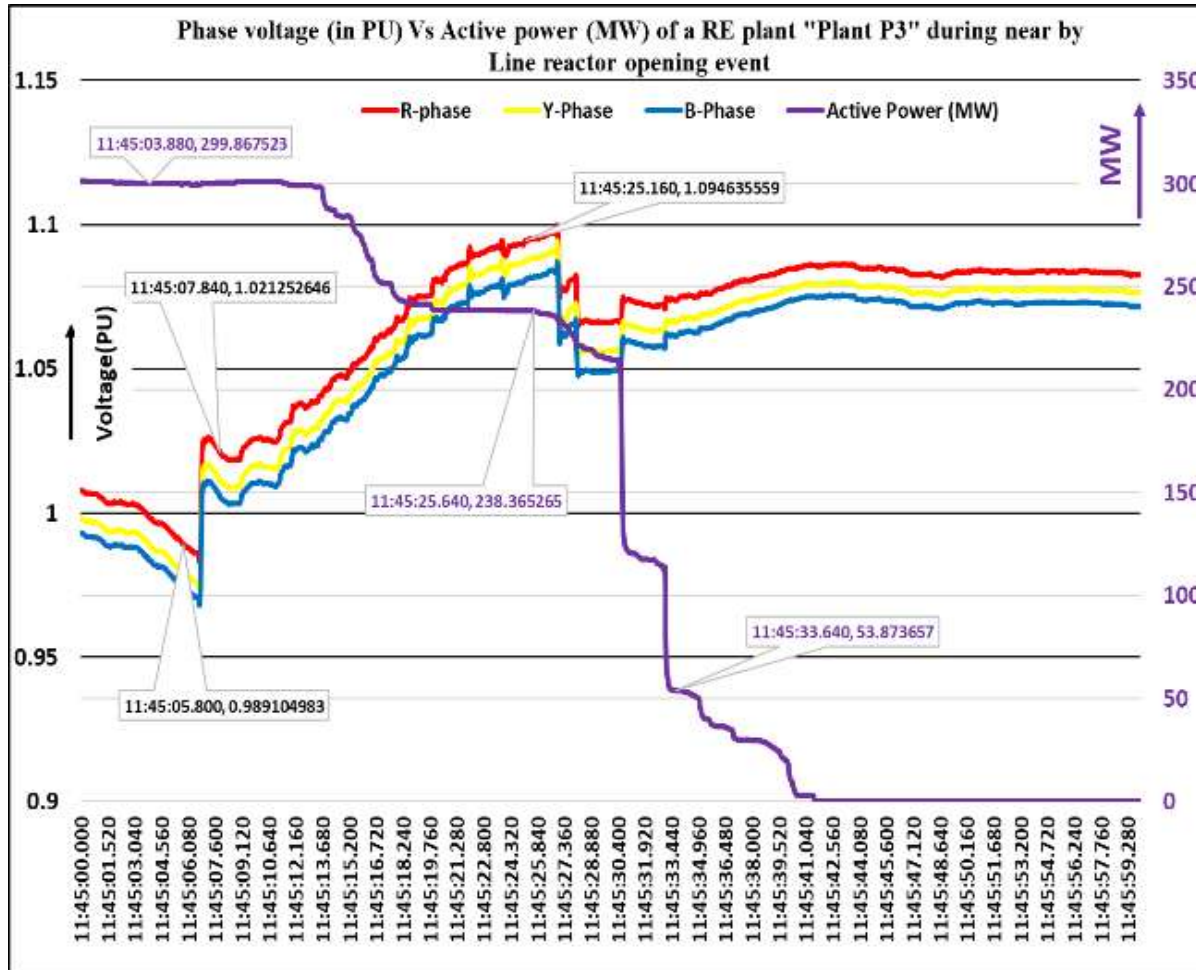

- ✓ Voltage shoot only from 0.99pu to 1.02pu (Shoot by 0.03pu) due to reactor opening. Further voltage raised to 1.095pu due to no MVAR absorption by RE plants despite high voltage and RE generation loss.
- ✓ Here, PPC should come into action ($1 < V_{POI} < 1.1$ pu) to absorb MVAR, undesirable action from PPC.
- ✓ Before tripping in OV, inverters must went in HVRT, it should absorb MVAR but no MVAR absorption observed.

Simulation based studies on a sample plant PSCAD model

A sample PSCAD equivalent model was developed for a 300MW RE plant. Simulation based studies are carried out to understand the performance of RE plant during fault and post-fault event. From the simulation studies, real-time generation loss event have been simulated to find out the probable cause and actions required to mitigate it.

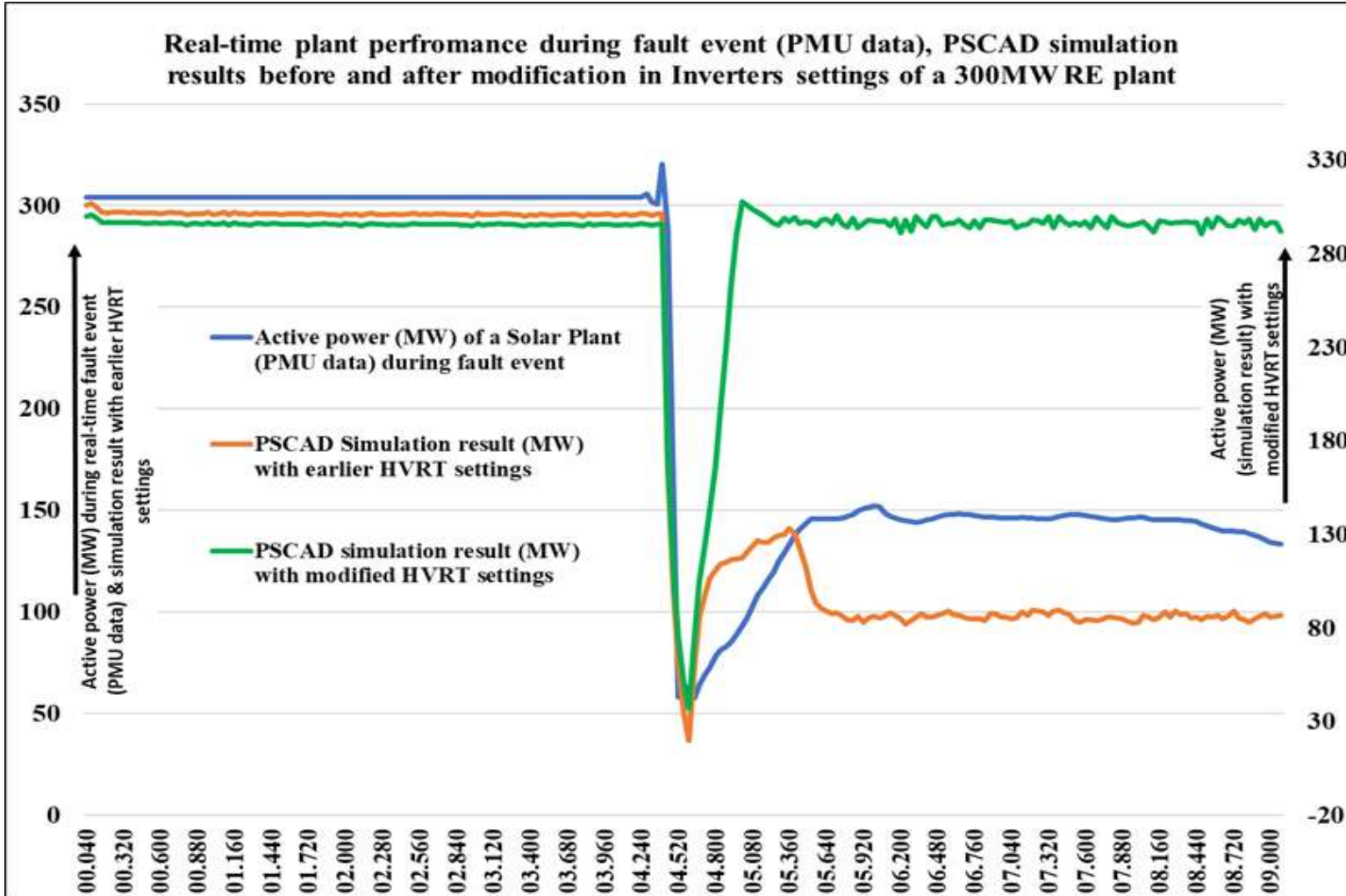

Active power (MW) recovery profile of a 300MW RE plant during real-time fault event (PMU data), PSCAD simulation result for active power (MW) with earlier and modified HVRT settings of Inverters.

From the above study, following observations were made:

1. As per PMU data, plant failed to recover pre-fault active power within 1 sec during real-time fault event, generation loss of ~50%.
2. As per PSCAD simulation, plant failed to recover pre-fault active power within 1 sec (Inverters directly going from LVRT to HVRT) with earlier (default) settings of Inverters, HVRT triggering threshold 1.1pu.
3. As per PSCAD simulation, plant successfully recovered the pre-fault active power within 1 sec with modified (enhanced) HVRT settings of Inverters. HVRT triggering threshold 1.15pu.

REAL-TIME RESPONSE OF RE PLANTS AFTER IMPLEMENTATION OF THE RECOMMENDED SETTINGS

Improvement in performance of plant (had issue of No recover or partial recovery of active power generation after clearance of fault)

Active power (MW) of a RE plant "Plant A" during nearby fault event with earlier O/V settings on 11th Aug'22 event

Active power (MW) of a RE plant "Plant A" during nearby fault event with modified O/V settings on 14th Jan'23 event

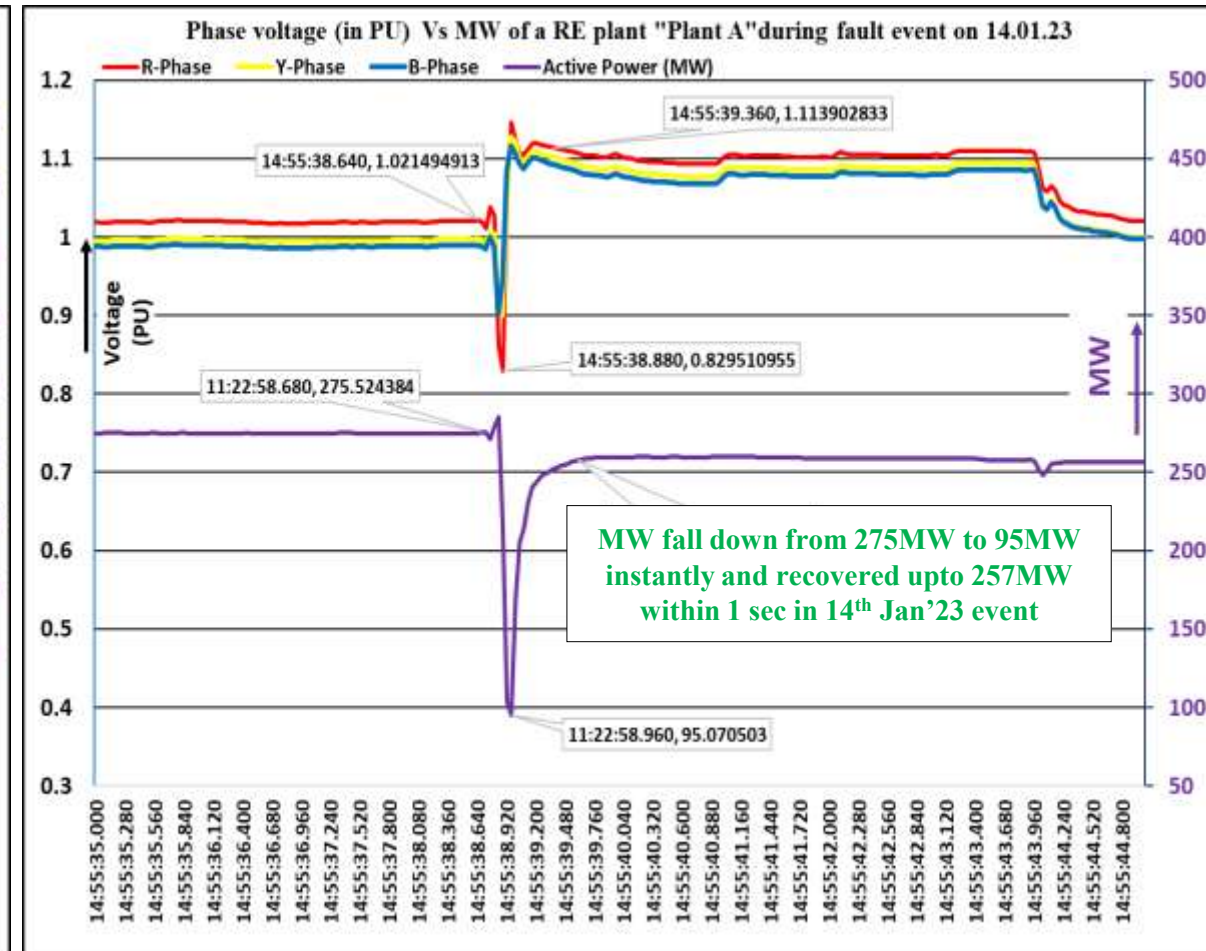
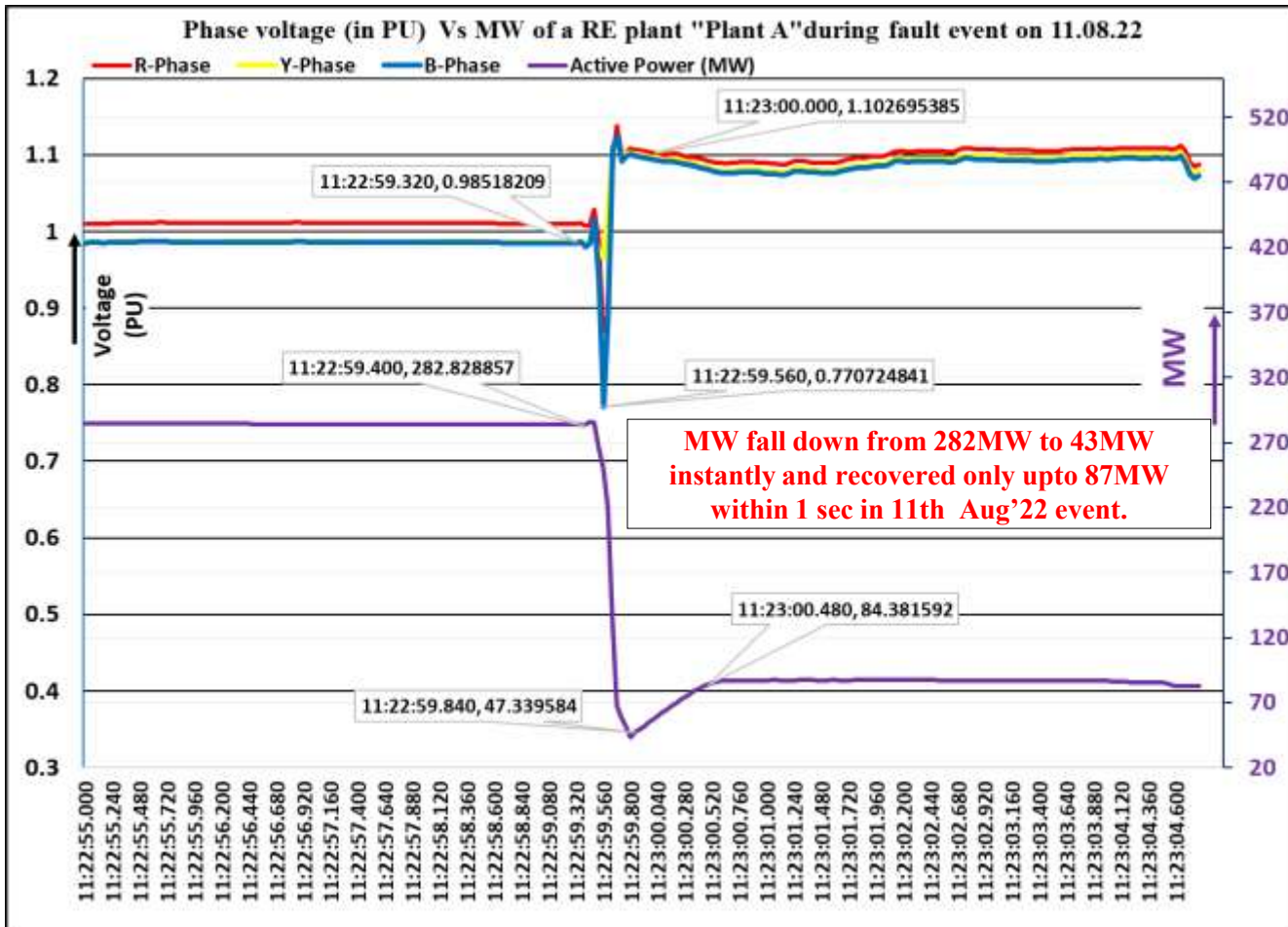

Comparison of active power (MW) recovery profile of RE plants with earlier and modified HVRT settings based on two different real-time fault events

REAL-TIME RESPONSE OF RE PLANTS AFTER IMPLEMENTATION OF THE RECOMMENDED SETTINGS

Improvement in performance of plant (had issue of Full recovery of pre-fault generation after fault clearance but generation loss after few seconds)

Active power (MW) of a RE plant "Plant B" during nearby fault event with earlier HVRT settings on 11th Aug'22 event

Active power (MW) of a RE plant "Plant B" during nearby fault event with modified HVRT settings on 14th Jan'23 event

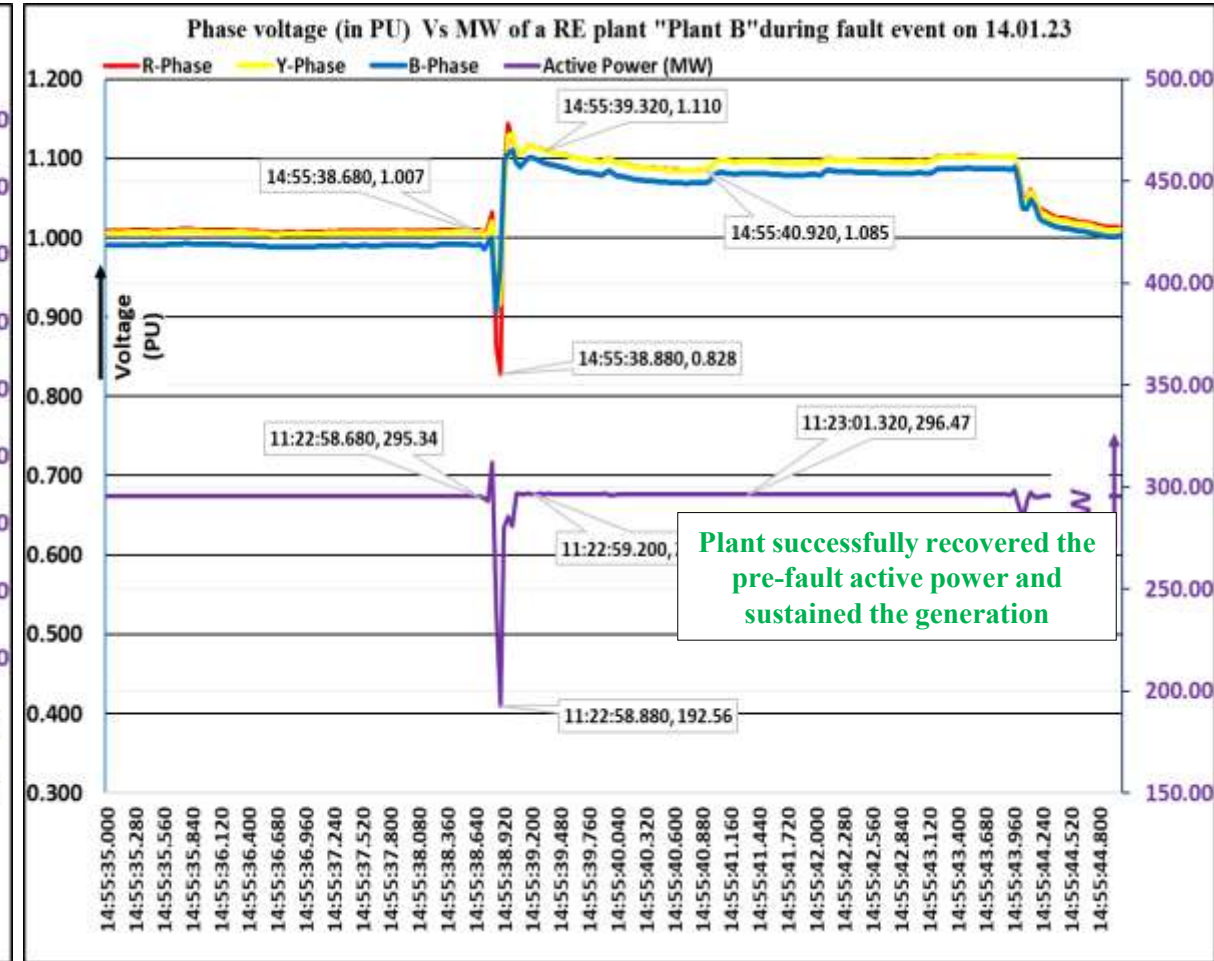
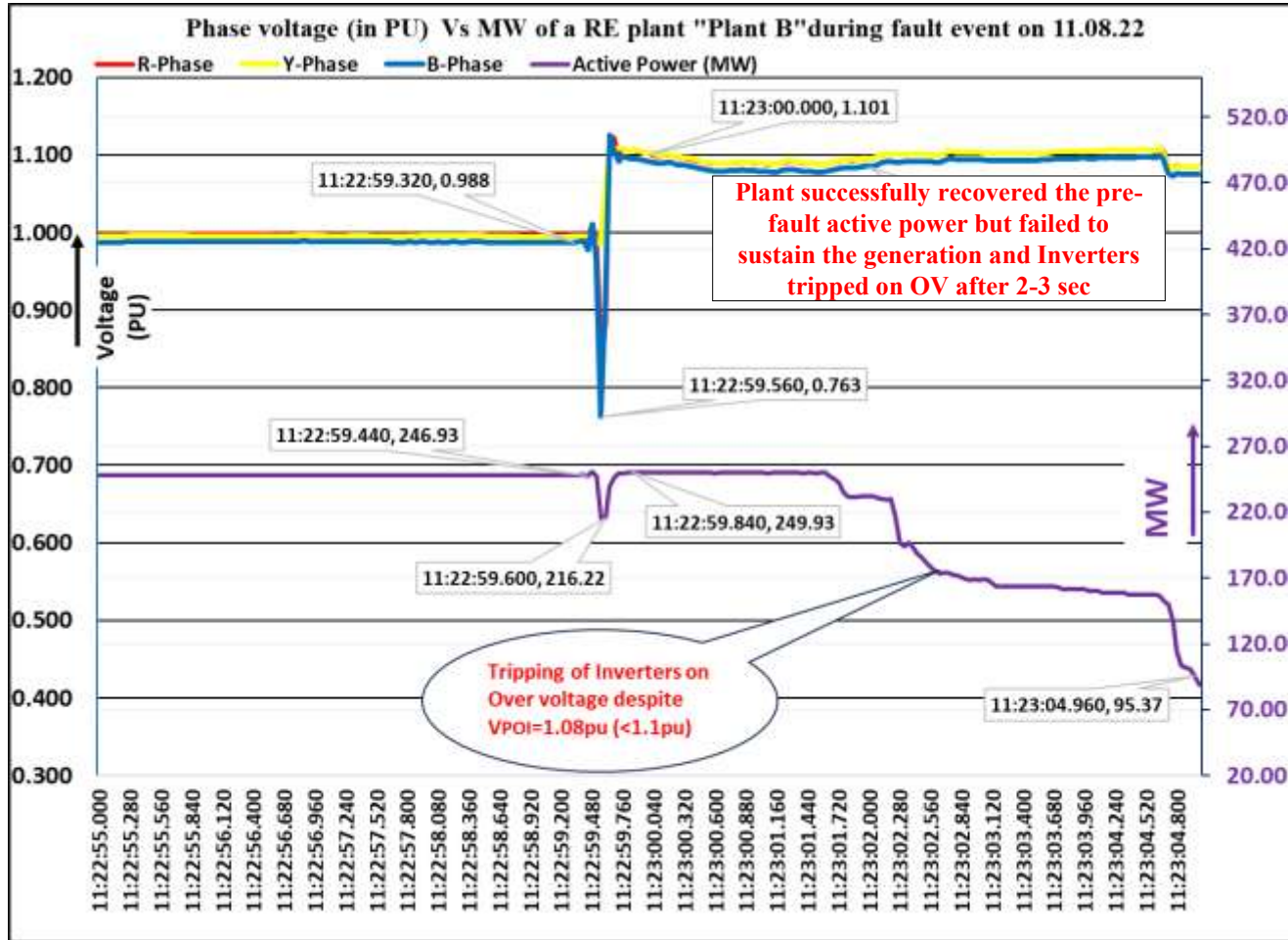

Comparison of active power (MW) recovery profile of RE plants with earlier and modified Over voltage settings based on two different real-time fault events

RE Generation Loss Events – Revision in Settings

Inverters Name	Issues observed	Actions Taken
SUNGROW SG4400UD-20, SG3300UD-20, SG1100UD-20 Inverters	After several meetings with developers and OEM (Sungrow), it was found the frequency and df/dt protection is being operated based on single cycle measurement instead of average of 5-6 cycle. Hence, in case of any voltage distortion during any fault event for just one cycle, it may cause the tripping of inverter on df/dt protection	OEM disabled the df/dt and active islanding protection in all the Sungrow SG4400UD-20 inverters
SUNGROW SG250HX-IN	SUNGROW SG250HX-IN inverters have the following issue: <i>"In case of any disturbance its internal cycle wrongly crosses zero (wrong Zero crossing) and inverters get tripped on abnormal frequency despite frequency remains normal operating range"</i>	1.Disabled df/dt setting in all Sungrow SG250HX-IN inverters. 2. Upgradation of firmware with optimization of Transient Protection Logic & Wave by wave fast protection logic in all Sungrow SG250HX-IN inverters
Several other inverters	Tripping on Over Voltage	O/V settings of Inverters changed from Stage-1: 1.1pu (2sec) to 1.15pu 10sec Stage-2: 1.2pu (200ms) to 1.20 pu (2000ms) Stage-3: 1.3pu (0 sec) to 1.3pu (200ms)

- *Inverters have multiple protections on which they might trip in case of undesirable settings, incorrect measurement etc.*
- *Plants have reported different reasons for tripping of inverters other than over/under voltage such as phase-jump, zero-crossing, over/under frequency, high ROCOF (df/dt), transient over-voltage etc.*
- *These protections are usually not represented in the simulation models leading to deviation in performance in real-time*

Commissioning of STATCOMs in Rajasthan REZ.....

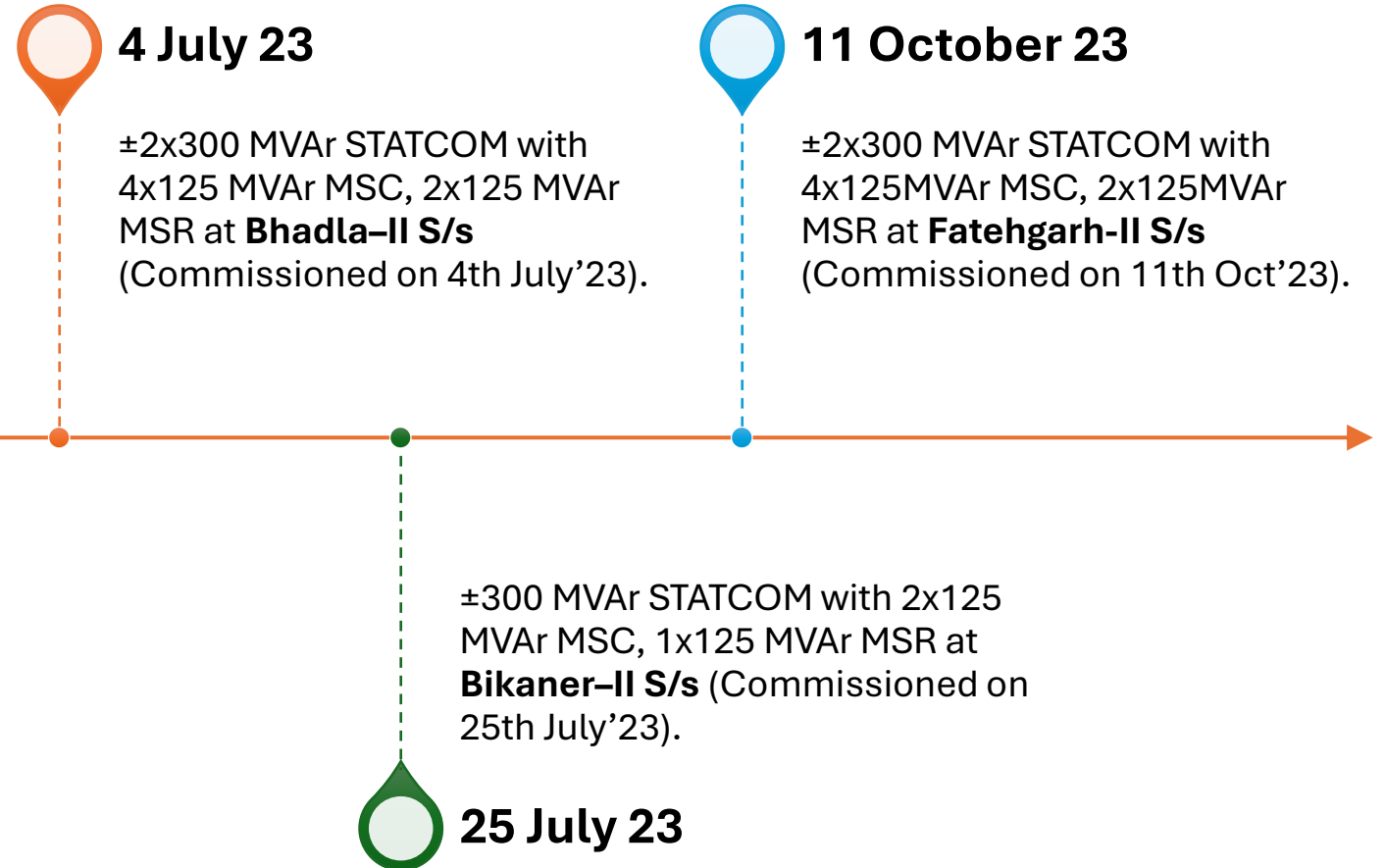

Summary of RE generation loss events

(>1000 MW ISTS Connected RE generation loss)

Year	Duration	Total Nos. of RE generation loss events took place	Maximum RE generation loss quantum (MW)	Average RE generation loss quantum (MW)	Installed capacity at the time of maximum generation loss (MW)
2022	01.01.2022-31.12.2022	15	6157	2533	12178
2023	01.01.2023-31.12.2023	17	7100	2964	12979
2024	01.01.2024-31.12.2024	19	4930	2175	16656
2025	01.01.2025-07.10.2025	4	2215	1584	20331

- Issue of LVRT/HVRT Non-compliance of ISGS RE plants in NR and generation loss in Rajasthan REZ during fault event is yet to be resolved completely, issue is being regularly followed-up in RE Sub-committee meeting of NRPC. Corrective measures needs to be implemented by concerned RE plants to ensure compliance of LVRT/HVRT.
- Issue of Reactive power injection by RE plants during fault events and Reactive power absorption during high voltage is still the major cause of concern-more actions required in this area.

15th May 2023 event: 7120 MW loss with frequency dip to 49.40 Hz. Further reduction of frequency was arrested by UFR (4000 MW load shedding)

Impact of deviation due to Inaccuracy in Forecasting (Cloudy Day)

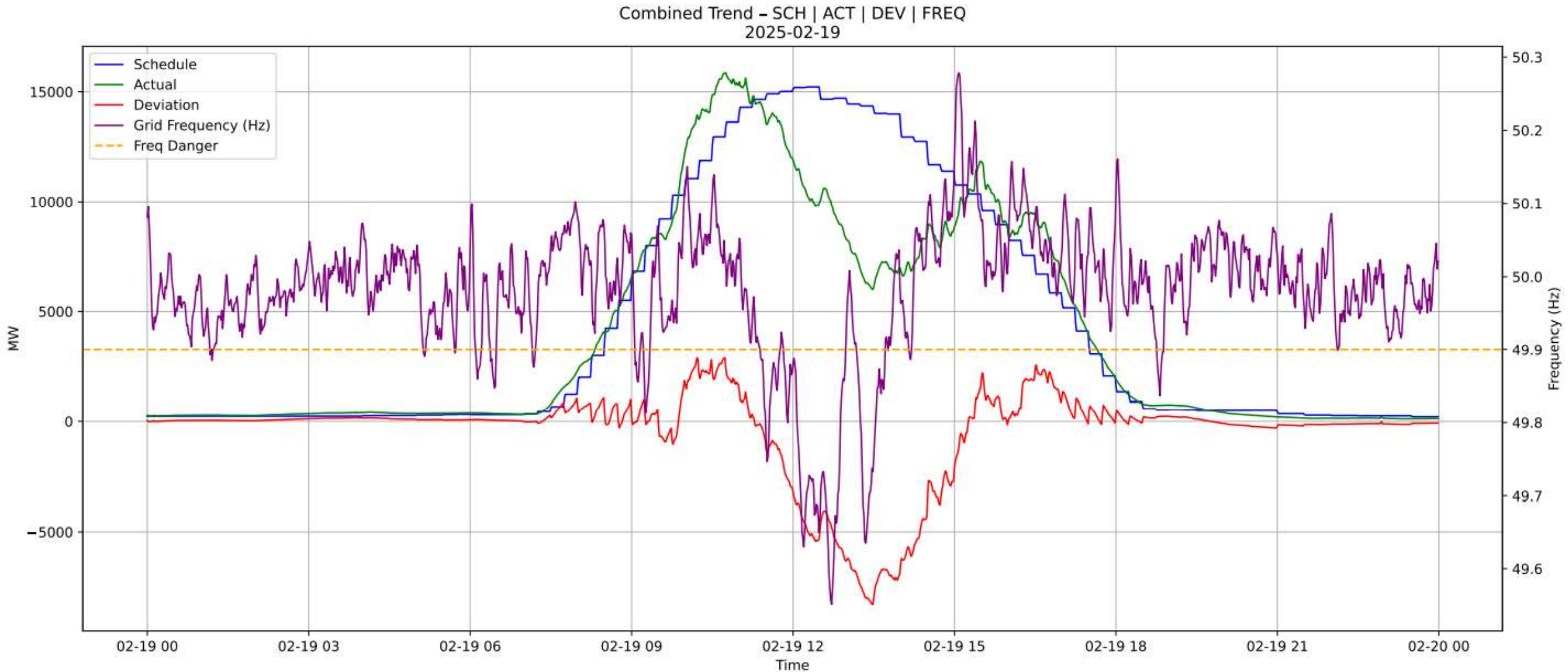

Impact of deviation due to Inaccuracy in Forecasting (Foggy Day)

Combined Trend - SCH | ACT | DEV | FREQ
2025-01-13

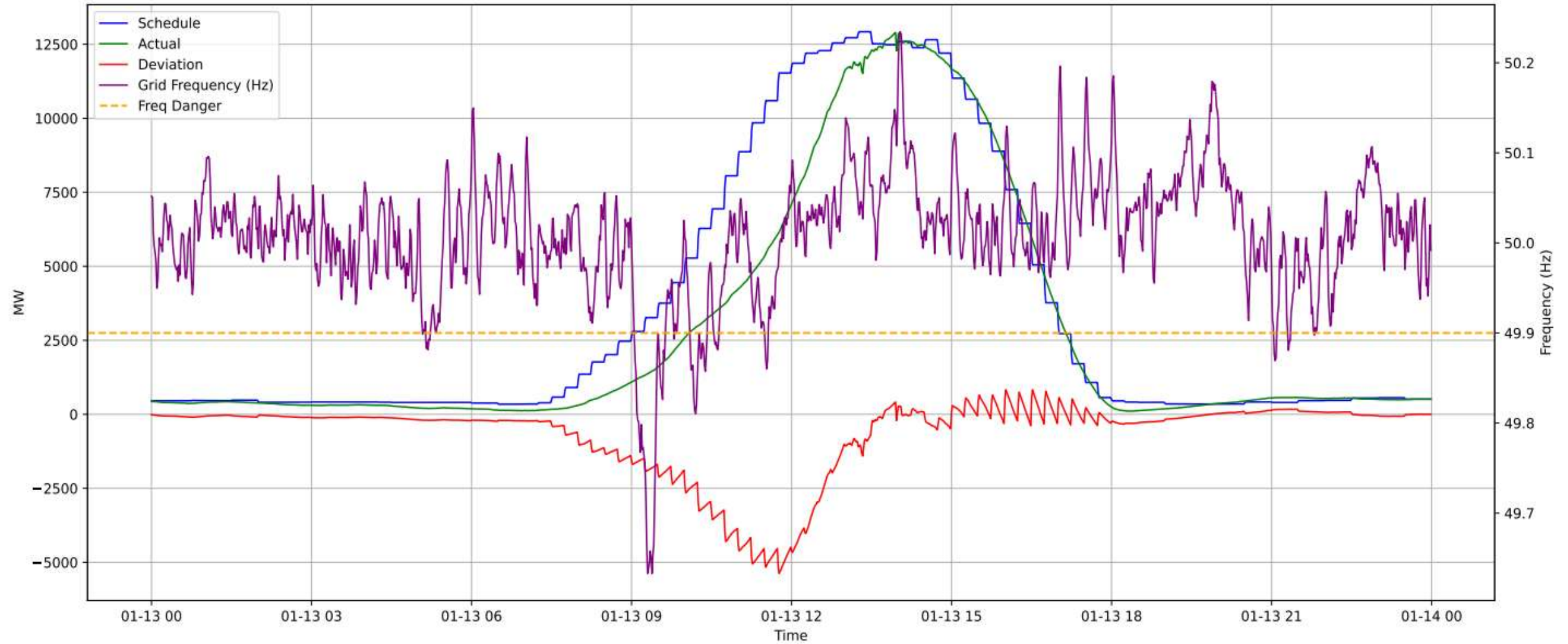

Uncertainty in Solar and Wind Generation

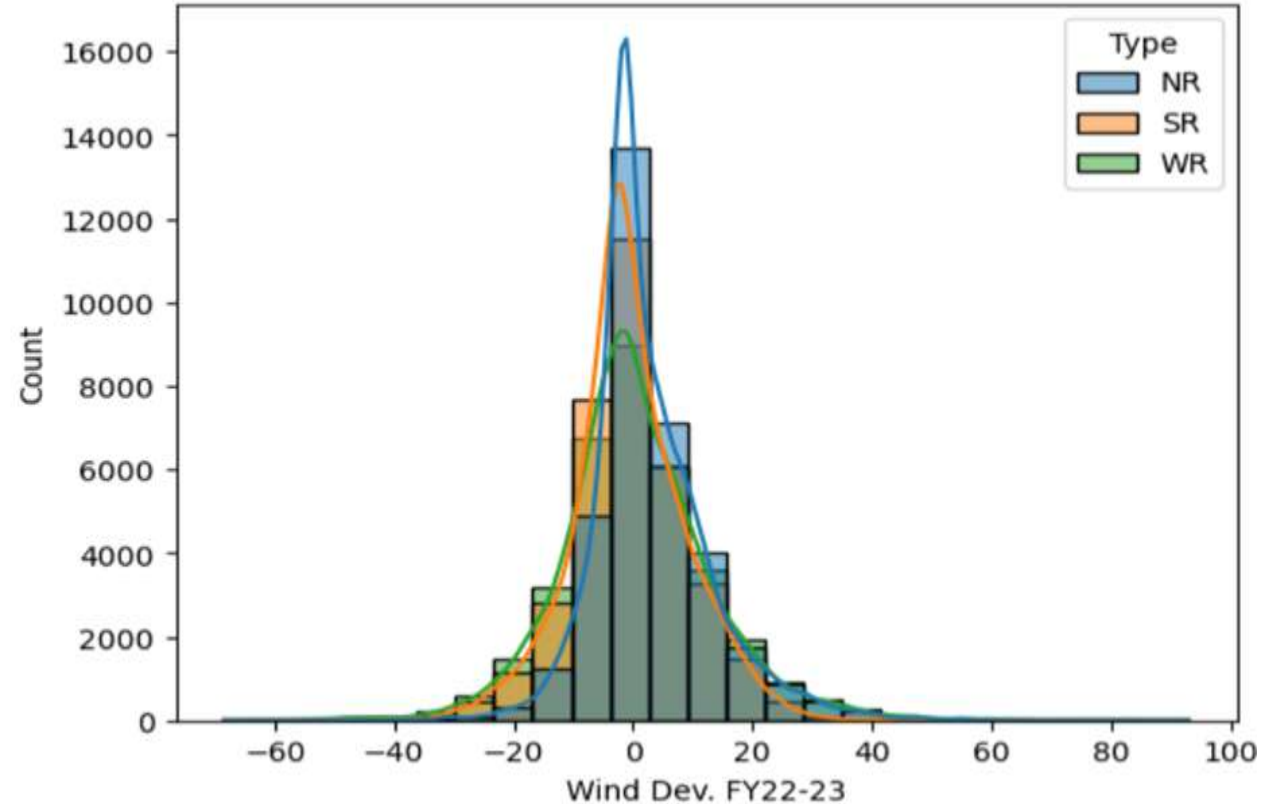
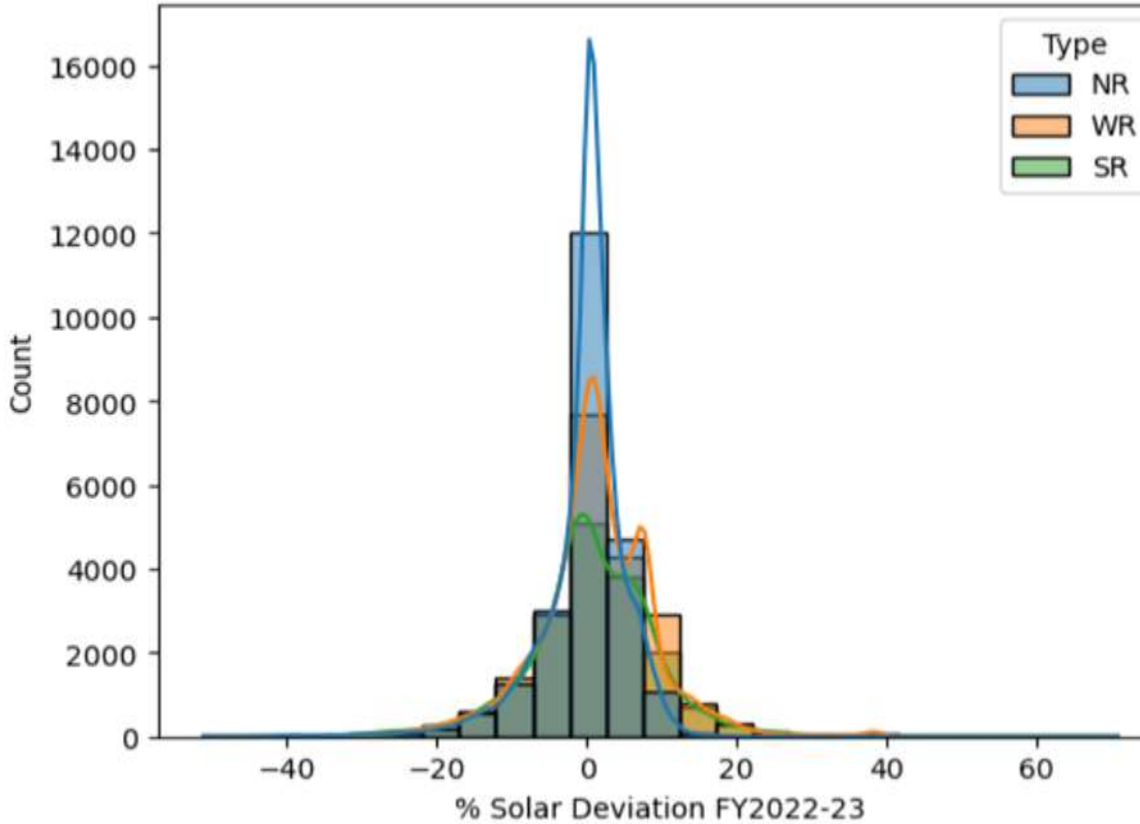

Solar Generation mainly depends on GHI/GII, Temperature, Type of Tracking\Tilting, Fog(Humidity\Temperature\Wind Speed\Aerosol), Cloud Formation and Wind Direction.

Wind Generation mainly depends on wind Speed, Air Density, Wind Direction, Velocity components etc.

Way Forward

- **Reliability in Operations Phase**
- Forecasting Accuracy and Scheduling
- Coordination during real-time operations
- Approach to multiple source of weather data.
- Improvement in models

Role of Batteries in Stability of Grid

- ✓ **Frequency Stability:-** As a load & generation balance component, Battery has capability to provide the Primary, Secondary and Tertiary Response for frequency stability of the grid.
 - ✓ **Increased Margin:-** Batteries commissioned in RE generation pocket will be tentatively charge during low price/RE generation hours which will enable more margin to inject RE power in the grid.
 - ✓ **Voltage Stability:-** Battery has the circular reactive power capability curve with radii dependent upon current running active power. It has the capability to operate supportively in any voltage scenarios.
 - ✓ **Locally Schedule-Actual Balance:-** Co-located Solar/Hybrid projects with Battery will feel less penalties for their Deviation(DSM Regulation). Further, Batteries are to provide support in load generation balance.
-
- ❖ **Control Interactions:-** Batteries may introduce more control interactions.

Q&A

You have

Questions

We have

Answers

Thank You